

Built-in Amplifier Photoelectric Sensor

E3V3

Easy-to-use, Low-cost Photoelectric Sensor

- Incorporating indicators that can be clearly seen from a distance
- Conforms to EN and IEC standards
- Incorporating polarizing function, thus accurately detecting lustrous objects
- Resin-filled construction resists vibration and ensures IP67 water-resistance
- Replaces E3V sensor



Ordering Information

Connection Method	Appearance	Sensing Method	Detection Distance	Operating Mode	Output	
					NPN	PNP
Cord connection	Cord length: 2 m 	Through-beam	7 m (23 ft)	Light-ON Dark-ON (selectable by wiring)	E3V3-T61	E3V3-T81
		Retroreflective (polarized)	2 m (6.6 ft)		E3V3-R61	E3V3-R81
		Diffuse reflective	0.5 to 8 cm (0.20 to 3.15 in)		E3V3-D61	E3V3-D81
			70 cm (2.3 ft)		E3V3-D62	E3V3-D82

Note: Mounting brackets are not provided with the E3V3. Order them separately.

■ ACCESSORIES (ORDER SEPARATELY)

Attachments

Name	Remarks	Part Number
Retroreflector	Corner cube reflector	E39-R3
Retroreflector (tape type)	Glass bead adhesive back	E39-RSA, E39-RSB
Slit for Through-beam Sensor	0.5, 1, 2 dia. slits	E39-S7

Mounting Brackets

Part Number	Remarks
E39-L104	Standard vertical-mounting bracket
E39-L44	Rear-mounting bracket
E39-L43	Side-mounting bracket
E39-L98	Metal cover
E39-L93	Sensor adjustor

E39-L104

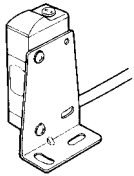

E39-L44

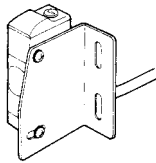

E39-L43

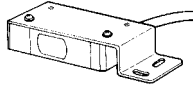

E39-L98

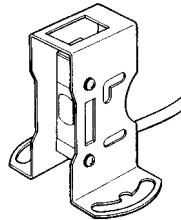

E39-L93

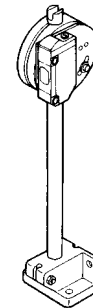

Application Examples

Detection of Cardboard Boxes

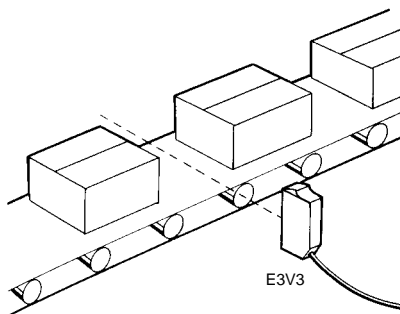

Detection of Labels

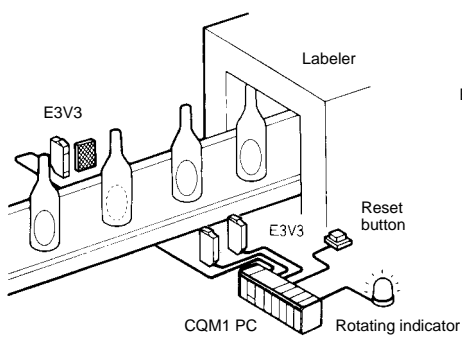

Detection of Automobiles at Indoor Parking Lots

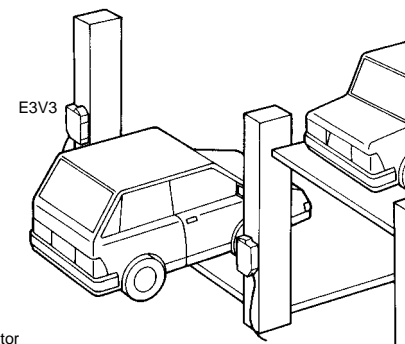

Specifications

Sensing Method		Through-beam	Retroreflective (with MSR function)	Diffuse Reflective	
NPN output		E3V3-T61	E3V3-R61	E3V3-D61	E3V3-D62
PNP output		E3V3-T81	E3V3-R81	E3V3-D81	E3V3-D82
LED light source		Infrared LED	Red LED	Infrared LED	
Sensitivity adjustment		Adjustor			
Connection method		Drawing cord-Standard length: 2 m (6.6 ft)			
Weight		Approx. 160 g (with 2-m cord)	Approx. 80 g (with 2-m cord)		
Control output selection		Cord wiring method (Light-ON or Dark-ON)			
Circuit protection		Overload protection, reversed connection protection, and mutual interference prevention function (except for through-beam models)			
Indicators		Operation indicator (orange), stability indicator (green), emission indicator for through-beam models only (orange)			
Materials	Case	Heat-resistive ABS			
	Lens	Methacrylic resin			
Attachments		Instruction sheet and reflector (E39-R1 retroreflective model only) (see note)			

Note: The mounting brackets are sold separately.

■ RATINGS/CHARACTERISTICS

Sensing Method		Through-beam	Retroreflective (with MSR function)	Diffuse Reflective	
Part number		E3V3-T61/-T81	E3V3-R61/-R81	E3V3-D61/-D81	E3V3-D62/-D82
Power supply voltage		12 to 24 VDC \pm 10%, ripple (p-p): 10% max.			
Current consumption		50 mA max.	40 mA max.		
Detection distance		7 m	0.1 to 2 m (with E39-R1)	0.5 to 8 cm	70 cm
Standard detectable object		Opaque object: 7 mm min. (0.28 in)	Opaque object: 30 mm min. (1.18 in)	10 x 10 cm white paper	20 x 20 cm white paper
Directional angle		3° to 15°	Receiver/Emitter: 2° to 10° Reflector: 30° min.	---	
Differential travel		---		20% max. of detection distance	
Response time		1 ms max. for both operation and release			
Control output		100 mA max. at 30 VDC, open collector output (residual voltage: 1 V max.)			
Ambient illumination	Incandescent lamp	Illumination on optical spot: 3,000 lx max.			
	Sunlight	Illumination on optical spot: 10,000 lx max.			
Ambient temperature	Operating	-25°C to 55°C (-13°F to 131°F) with no icing			
	Storage	-40°C to 70°C (-40°F to 158°F)			
Ambient humidity	Operating	35% to 85%			
	Storage	35% to 95%			
Insulation resistance		20 M Ω min. (at 500 VDC)			
Dielectric strength		1,000 VAC, 50/60 Hz for 1 min			
Vibration resistance	Destruction	10 to 55 Hz, 1.5-mm double amplitude for 2 hrs each in X, Y, and Z directions			
Shock resistance	Destruction	500 m/s ² (approx. 50G) 3 times each in X, Y, and Z directions			
Enclosure rating	IEC	IP67			

Retroreflector Specifications

Item	E39-R3	E39-RSA	E39-RSB
Detection distance (with E3V3)	5 to 100 cm	20 to 50 cm	20 to 80 cm
Directional angle	30° min.		
Ambient temperature	Operating	-25°C to 55°C (-13°F to 131°F)	
	Storage	-40°C to 70°C (-40°F to 158°F)	
Ambient humidity	Operating	35% to 85%	
	Storage	35% to 95%	
Enclosure rating	IEC	IP67 (see note 2)	

- Note: 1. The E39-R3, E39-RSA, and E39-RSB are polarizing reflectors.
 2. Do not cut or scratch E39-R3, E39-RSA, or E39-RSB Reflectors, otherwise they will not be water resistant.

Engineering Data

■ **PARALLEL OPERATING RANGE (TYPICAL)**

E3V3-T□1

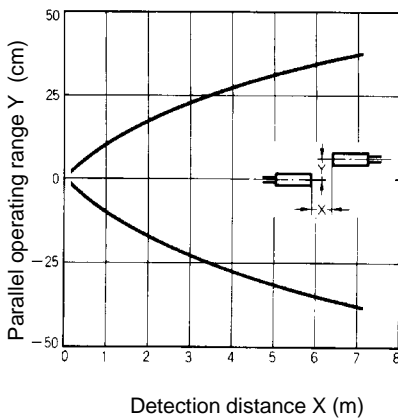

■ **REFLECTOR PARALLEL MOVEMENT (TYPICAL)**

E3V3-R□1

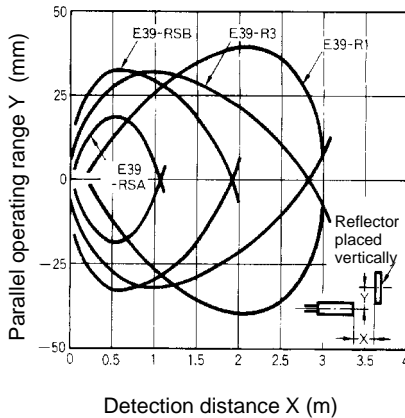

■ **OPERATING RANGE (TYPICAL)**

E3V3-D□2

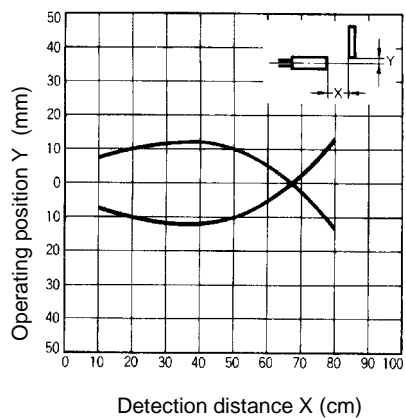

■ **DETECTION DISTANCE VS. OBJECT SIZE (TYPICAL)**

E3V3-D□2

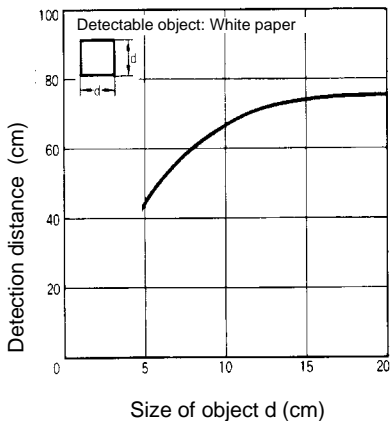

■ **COLOR OF OBJECT VS. OPERATING RANGE (TYPICAL)**

E3V3-D□1

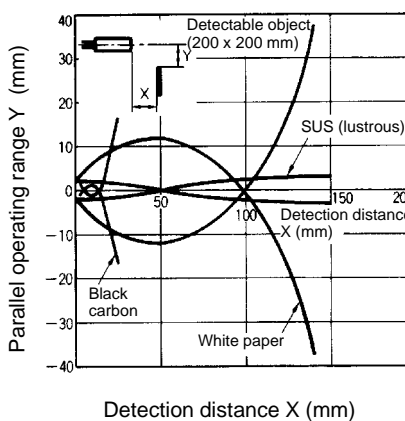

■ **DETECTION DISTANCE VS. OBJECT SIZE (TYPICAL)**

E3V3-D□1

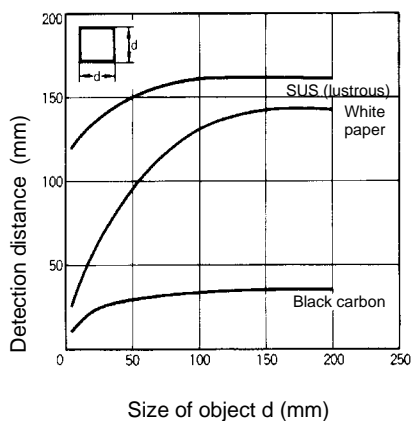

■ EXCESS GAIN VS. SET DISTANCE (TYPICAL)

E3V3-T□1

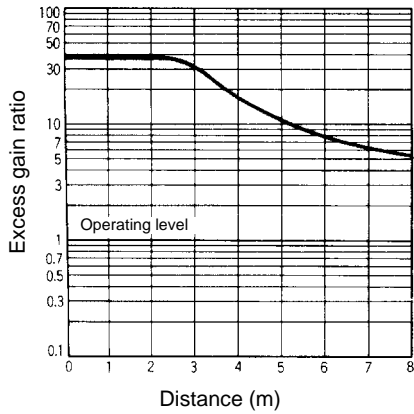

E3V3-R□1

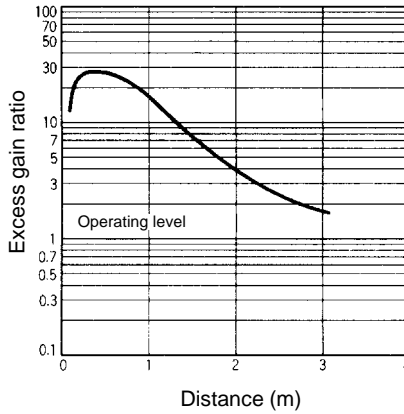

E3V3-D□2

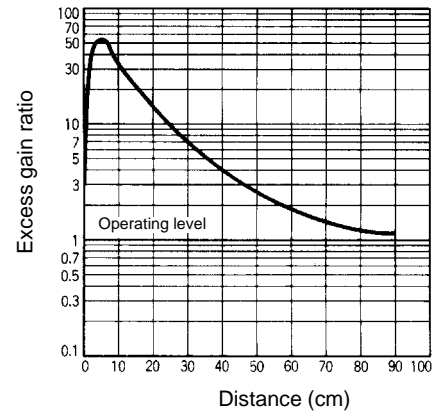

E3V3-D□1

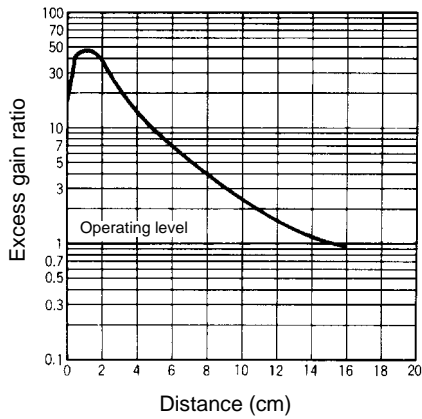

Operation

■ OUTPUT CIRCUITS

Output Configuration	Mode Switch	Connection Method	Output Circuits
NPN (E3V3-□6□)	Light-ON	Connect the pink cord to the brown cord. (see note)	
	Dark-ON	Connect the pink cord to the blue cord or disconnect the pink cord from the blue cord. (see note)	

Output Configuration	Mode Switch	Connection Method	Output Circuits
PNP (E3V3-□8□)	Light-ON	Connect the pink cord to the brown cord. (see note)	
	Dark-ON	Connect the pink cord to the blue cord or disconnect the pink cord from the blue cord (see note)	

Note: The E3V3 Model with a junction connector has a white cord instead of a pink cord.

Emitter (NPN/PNP)

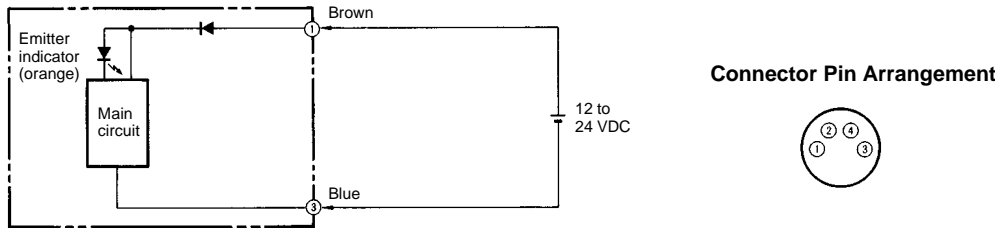

■ TIMING CHARTS

Output Configuration	Mode Switch	Connection Method	Timing Chart
NPN (E3V3-□6□)	Light-ON	Connect the pink cord to the brown cord. (see note)	<p style="text-align: right;">(Between brown and black)</p>
	Dark-ON	Connect the pink cord to the blue cord or disconnect the pink cord from the blue cord. (see note)	<p style="text-align: right;">(Between brown and black)</p>
PNP (E3V3-□8□)	Light-ON	Connect the pink cord to the brown cord. (see note)	<p style="text-align: right;">(Between blue and black)</p>
	Dark-ON	Connect the pink cord to the blue cord or disconnect the pink cord from the blue cord. (see note)	<p style="text-align: right;">(Between blue and black)</p>

Note: The E3V3 Model with a junction connector has a white cord instead of a pink cord.

■ SENSITIVITY ADJUSTMENT (REFLECTIVE SENSORS)

(Diffuse reflective model in light-ON mode)

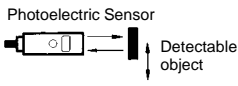
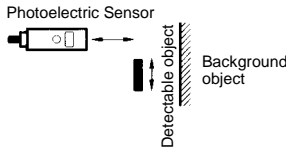
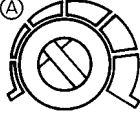
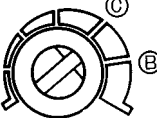
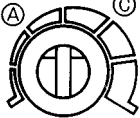
Item	Position A	Position B	Setting
Sensing condition	 <p>Photoelectric Sensor Detectable object</p>	 <p>Photoelectric Sensor Detectable object Background object</p>	---
Sensitivity adjustor			
Indicators	<p>OFF ON</p> <p>○ STABILITY (green) ● OPERATION (orange)</p>	<p>OFF OFF</p> <p>○ STABILITY (green) ○ OPERATION (orange)</p>	<p>OFF ON</p> <p>● STABILITY (green) ○ OPERATION (orange)</p>
Procedure	<p>Locate the sensing object at the detection distance of the E3V3 and turn the sensitivity adjustor clockwise to increase the sensitivity of the E3V3 until the orange operation indicator is lit. The moment the orange operation indicator is lit, stop turning the sensitivity adjustor, the position of which is point A.</p>	<p>Remove the sensing object and turn the sensitivity adjustor clockwise until the E3V3 detects the background object and the orange operation indicator is lit. The moment the orange operation indicator is lit, stop turning the sensitivity adjustor, the position of which is point B. Turn the sensitivity adjustor counterclockwise to decrease the sensitivity of the E3V3 until the orange operation indicator is off. The moment the orange operation indicator is off, stop turning the sensitivity adjustor, the position of which is point C. If there is no background object, point C is where the sensitivity adjustor is set to maximum.</p>	<p>Set the sensitivity adjustor midway between points A and C, where the best sensitivity of the E3V3 for the sensing object is ensured, and make sure that the green stability indicator is lit with and without the sensing object at that position of the sensitivity adjustor. If the green stability is not lit, try another sensing method.</p>

Note: The rotation range of the sensitivity adjustor is 240°. Do not try to turn the sensitivity adjustor clockwise or counterclockwise excessively, otherwise the sensitivity adjustor will break.

■ ATTACHMENT

E39-R1 Retroreflector

Provided with the E3V3-R61/-R81

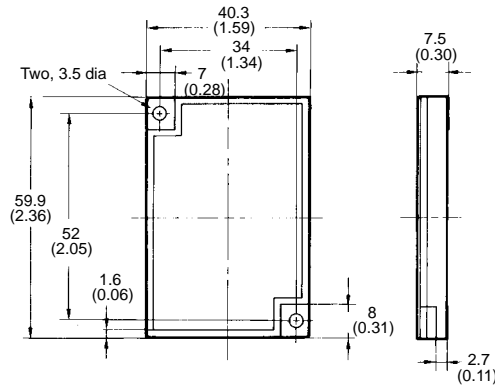

■ ACCESSORIES (ORDER SEPARATELY)

E39-R3 Retroreflector (Small Type)

With Mounting Bracket (Sold Together)

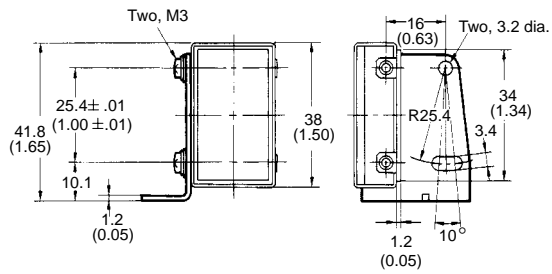
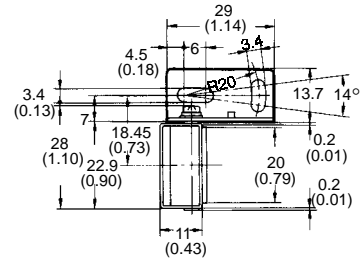
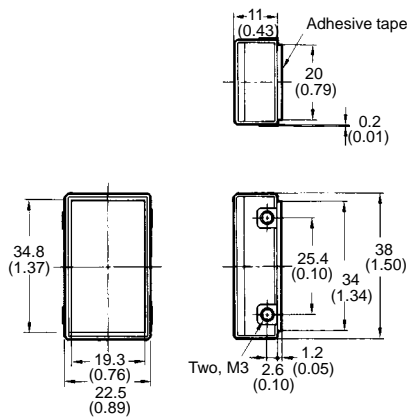

E39-RSA Retroreflector (Tape Type)

E39-RSB Retroreflector (Tape Type)

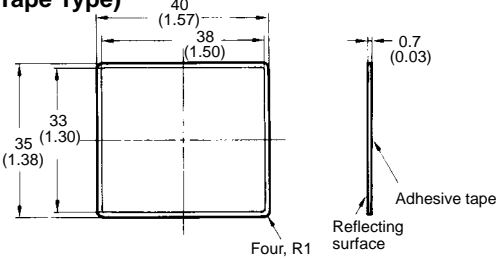
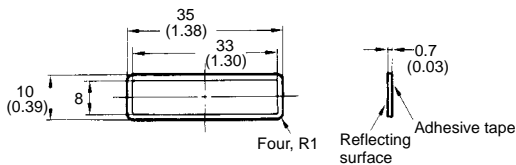

E39-L104 Mounting Bracket

With Mounting Bracket (E3V3-D62)

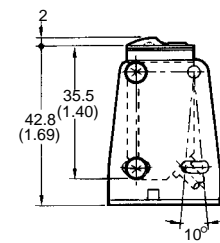
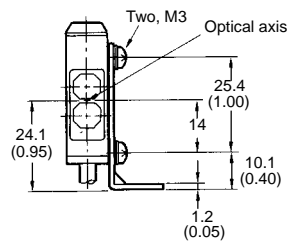
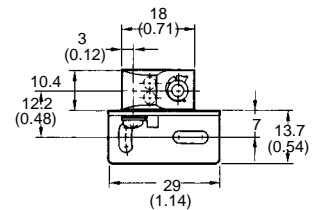
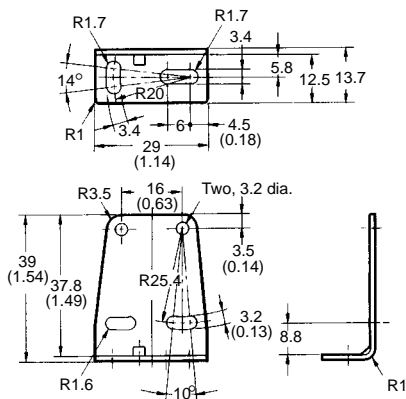

E39-L44

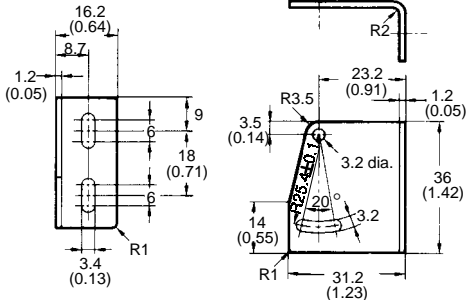

With Mounting Bracket (E3V3-D62)

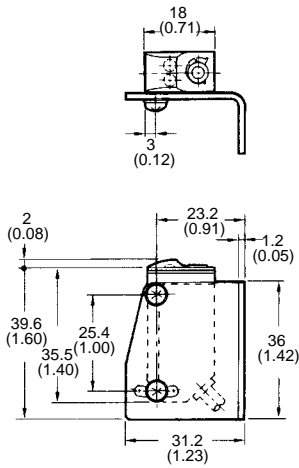
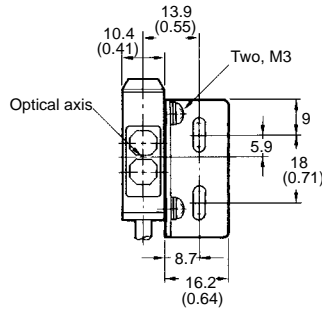

E39-L43

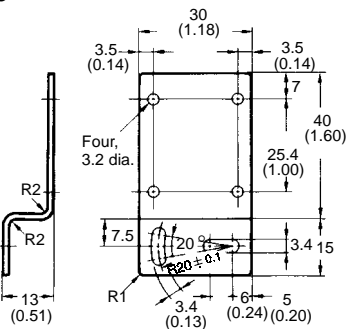

With Mounting Bracket (E3V3-D62)

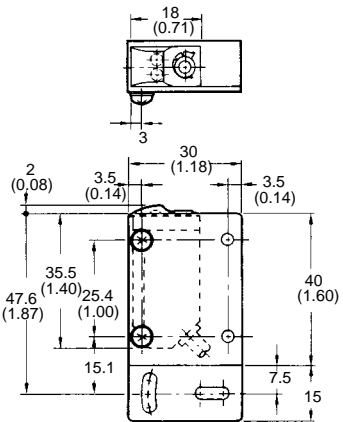
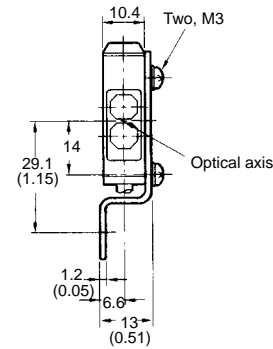

E39-L98

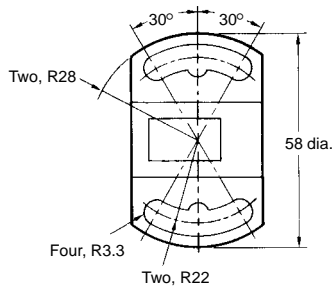

With Mounting Bracket (E3V3-D62)

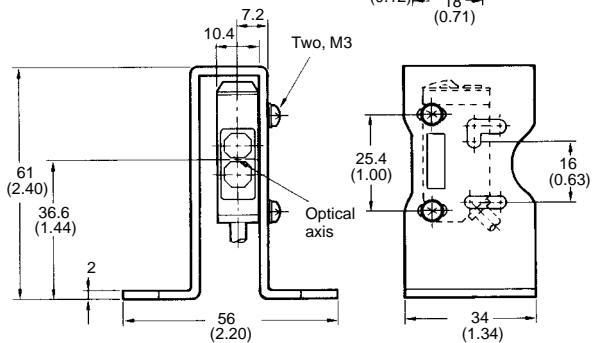
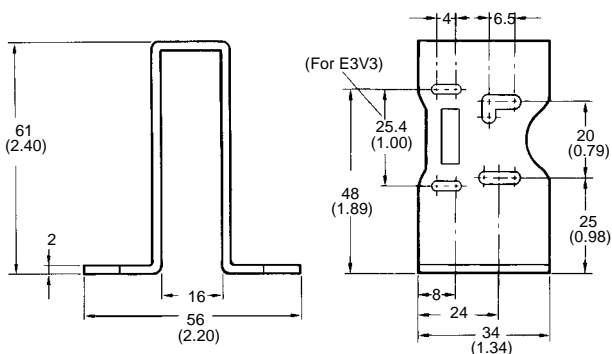
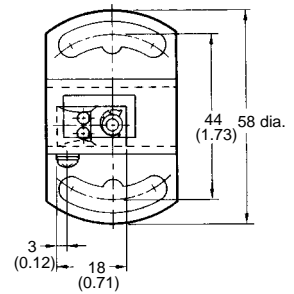

E39-L93

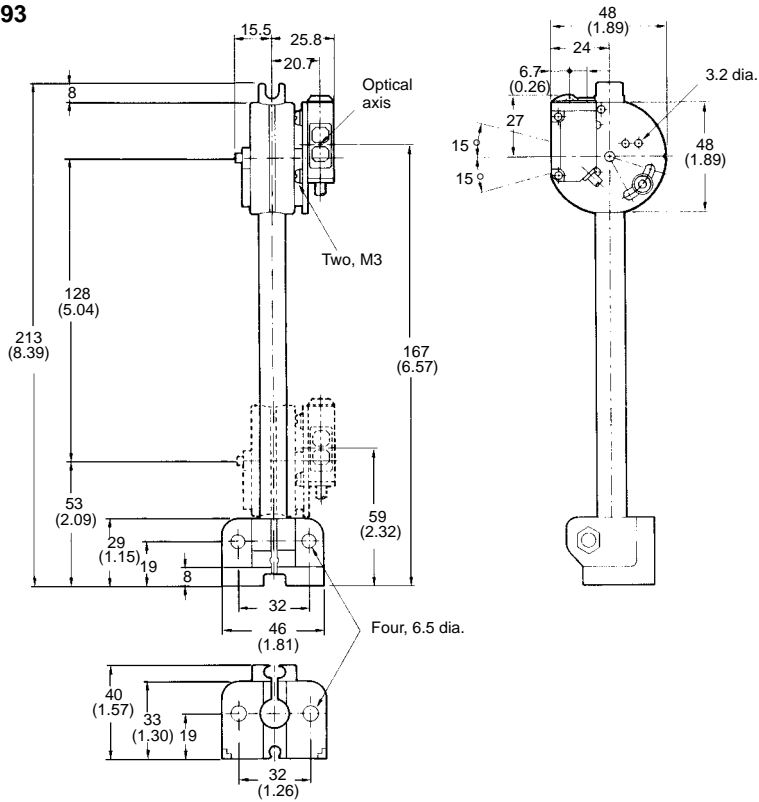

E39-S7 Slits for E3V3-T□□

(Two Pairs; a Total of 6 Slits)

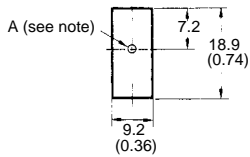

- Note:
1. A: 0.5, 1, or 2 dia.
 2. Attach an E39-S7 Slit to both the emission panel of the emitter and the receiver's sensing panel of the E3V3-T□□.

Detection Distance (Rating)

Item	Diameter	0.5 dia.	1 dia.	2 dia.
Slit attached	Emitter and receiver	25 mm (0.98)	100 mm (3.94)	400 mm (15.75)
	Receiver	400 mm (15.75)	800 mm (31.50)	1,500 mm (59.06)

Precautions

■ POWER SUPPLY

The permissible voltage imposed on the E3V3 must be 24 VDC + 10% maximum (i.e., 26.4 V). Make sure that the voltage imposed on the E3V3 is correct before turning the E3V3 on.

If a standard switching regulator is used as a power supply, the frame ground (FG) terminal and the ground (G) terminal must be grounded, or otherwise the E3V3 may malfunction due to the switching noise of the power supply.

■ OPERATION OF THE E3V3 WITH POWER TURNED ON

The E3V3 is ready to detect objects within 100 ms after the E3V3 is turned on. If the E3V3 and the load connected to the E3V3 each use an independent power supply, be sure to turn on the E3V3 first and then the load.

■ CONNECTION

If the input/output lines of the photoelectric sensor are placed in the same conduit or duct as power lines or high-voltage lines, the photoelectric sensor could be induced to malfunction, or even be damaged, by electrical noise. Either separate the wiring, or use shielded lines as input/output lines to the photoelectric sensor.

The cord connected to the E3V3 can be extended up to 100 m provided that the diameter of each wire of the cord is 0.3 mm² minimum.

■ WATER RESISTANCE

Do not use the E3V3 in water, in the rain, or outdoors.

■ MOUNTING

When mounting the E3V3, do not hit the E3V3 with a hammer, or the E3V3 will lose watertightness.

Use M3 screws to mount the E3V3.

Move the E3V3 up, down, left, and right to find the range where the operating indicator is lit or unlit. Then locate the E3V3 in the center of the range, at which time make sure that the stability indicator is lit.

■ PRECAUTIONS WHEN USING THE E39-R3, E39-RSA, OR E39-RSB REFLECTOR

Before applying adhesive tape to the reflector, make sure that the reflector is free from oil or dust, or otherwise the adhesive tape will not stick to the reflector properly.

Do not cut or scratch the reflector or the reflector will lose watertightness.

Do not press the reflector with a metal object or a nail, otherwise the reflector will not function properly.

WARNING

The E3V3 is not a safety component for ensuring the safety of people as defined in EC directive 91/368/EEC, or as covered by separate European standards or by any other regulations or standards.

NOTE: DIMENSIONS SHOWN ARE IN MILLIMETERS. To convert millimeters to inches divide by 25.4.

OMRON[®]

OMRON ELECTRONICS, INC.

One East Commerce Drive

Schaumburg, IL 60173

1-800-55-OMRON

OMRON CANADA, INC.

885 Milner Avenue

Scarborough, Ontario M1B 5V8

416-286-6465