

Micro Inductive Proximity Sensor

E2R

Low-end, Flat-type Proximity Sensor

- Flat sensor with a thickness of 6 mm.
- Enclosure rating: IEC IP50
- Non-contact sensor assuring a long service life.
- Assures high-response with a frequency of 5 kHz.

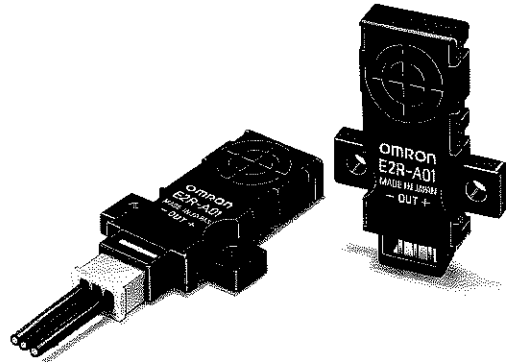

Ordering Information

Sensing head	Sensing distance	Output configuration	Model
Non-shielded 	5 mm	NO	E2R-A01

Connector

Appearance	Cable length	Model
	1 m	E22-01

Specifications

■ Ratings/Characteristics

Supply voltage (operating voltage)	12 to 24 VDC $+15\%/_{-10\%}$, ripple (p-p): 10% max.
Current consumption	8 mA
Detectable object	Magnetic metals (refer to "Engineering Data" for non-magnetic metals)
Sensing distance	5 mm $\pm 15\%$
Setting distance (standard object)	0 to 3.4 mm (Iron, 18 x 18 x 1 mm)
Differential travel	10% max. of sensing distance
Response frequency (see note)	5 kHz min.
Operation (with sensing object approaching)	Load ON
Control output	NPN open collector, 100 mA max.
Indicators	Operation indicator (red LED)
Ambient temperature	Operating: -10 to 55 °C (with no icing)
Ambient humidity	Operating: 35% to 85% (with no condensation)
Temperature influence	$\pm 20\%$ max. of sensing distance within a temperature range of -10 to 55 °C based on the sensing distance at a temperature of 23 °C.
Voltage influence	$\pm 2.5\%$ max. of sensing distance within a range of $\pm 10\%$ of rated voltage
Residual voltage	1.0 V max. (under load current of 100 mA with cable length of 1 m)
Insulation resistance	50 M Ω min. (at 500 VDC) between current carrying parts and case
Dielectric strength	1,000 VAC, 50/60 Hz for 1 min between current carrying parts and case
Vibration resistance	Destruction: 10 to 55 Hz, 1.5-mm double amplitude for 2 hrs each in X, Y, and Z directions
Shock resistance	Destruction: 500 m/s ² (approx. 50G) for 3 times each in X, Y, Z directions
Enclosure rating	IEC IP50
Weight	Approx. 5.5 g
Material	Sensing surface: PBT resin Rear cover: ABS resin

Note: The response frequencies for DC switching are average values measured on condition that the distance between each sensing object is twice as large as the size of the standard object and the sensing distance set is half of the maximum sensing distance.

Engineering Data

Operating Range (Typical)

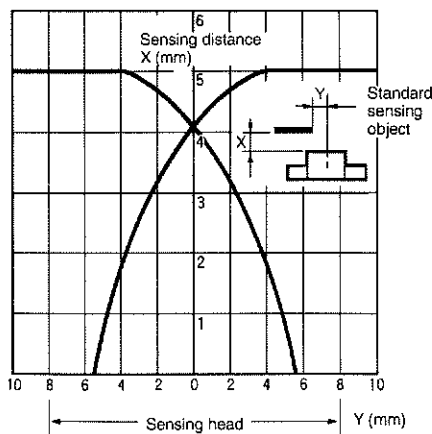

Sensing Distance vs. Sensing Object (Typical)

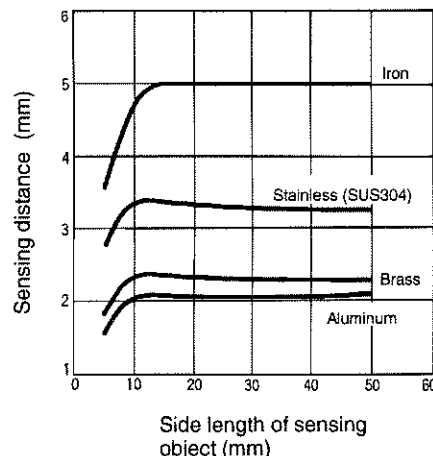

Operation

Output Circuit Diagram

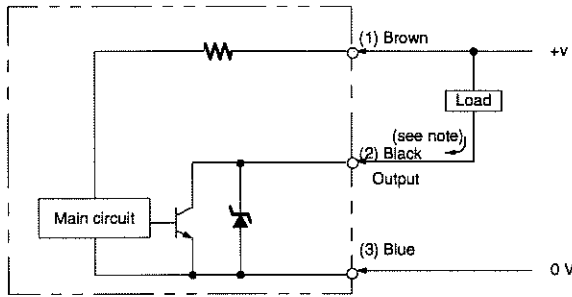

Sensing object	Yes	
	No	
Output transistor (load)	ON	
	OFF	
Operation indicator (LED)	ON	
	OFF	

Note: Load current: 100 mA max.

Dimensions

Note: All units are in millimeters unless otherwise indicated.

E2R-A01

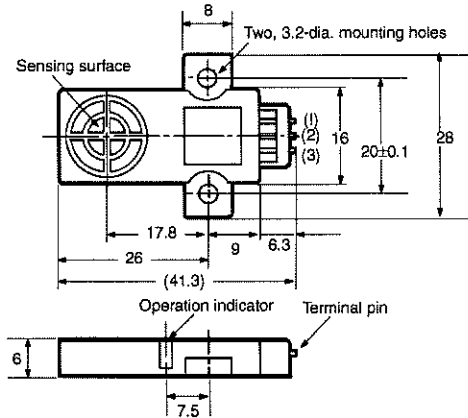
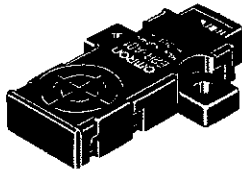

Mounting Holes

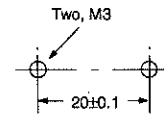

Terminal Arrangement

(1)	⊕	Power supply (+V)
(2)	OUT	Output
(3)	⊖	Power supply (0 V)

E22-01 Connector

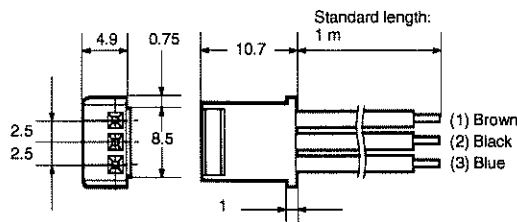
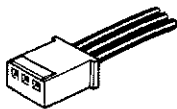

Note: Japan Molex's connector block (housing 5209-03 and terminal 5103) is used.

Precautions

Effects of Surrounding Metal

If there is any metal near the sensor, the metal may affect the performance of the E2R or the temperature of the metal may affect the sensing distance of the E2R. Make sure that the clearances given in the following illustrations are maintained for accurate sensing operation.

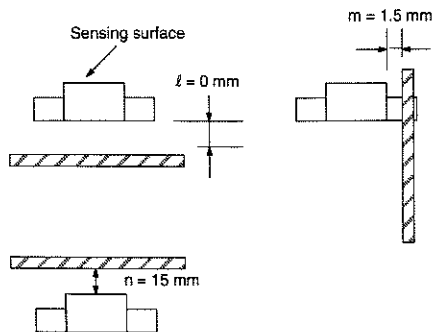

Mutual Interference

When installing two or more E2R units face to face or side by side, make sure that the minimum distances given in the following illustrations are maintained.

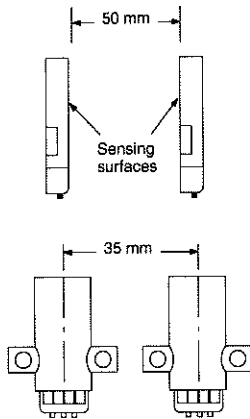

Handling and Connections

The E2R incorporates a connector. Do not solder connector pins to lead wires. Use the E22-01 Connector or Molex connector (housing 010308033 and terminal 008700057) or Japan Molex connector (housing 5209-03 and terminal 5103).

Do not impose external force on the terminal as shown in the following illustration, otherwise the terminal may be damaged.

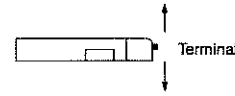

Do not connect or disconnect the connector with the E2R turned on, otherwise the E2R may be damaged.

Power Supply

When using a standard switching regulator with the E2R, ground the frame ground (FG) and ground (G) terminals of the switching regulator for stable operation.

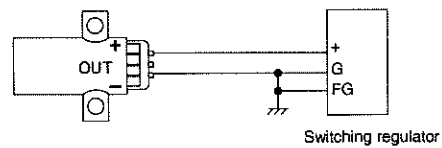

ALL DIMENSIONS SHOWN ARE IN MILLIMETERS.

To convert millimeters into inches, multiply by 0.03937. To convert grams into ounces, multiply by 0.03527.

Cat. No. D76-E1-1

In the interest of product improvement, specifications are subject to change without notice.

OMRON Corporation

Systems Components Division H.Q.
28th Fl., Crystal Tower Bldg.
1-2-27, Shiromi, Chuo-ku,
Osaka 540 Japan
Phone: 06-949-6012 Fax: 06-949-6021

Printed in Japan
0997-0.5M (0997) Ⓐ