

Mechanical Key Switch (Radial)

B3F-6

Taped Radial Switches

- Automatic mounting possible via general-purpose radial taped component inserters.
- Conform to EIAJ RC 1008A *Electronic Component Taping Dimensions*.
- The same snap-action contact construction as the B3F Series for a definite click action.
- Available with ground terminals for protection against static electricity.

Ordering Information

Type	Plunger	Height x pitch	Operating force (OF)		Without ground terminal	With ground terminal
			General purpose	High-force		
6 x 6 mm B3F-6000	Flat type	4.3 x 5.0 mm	General purpose	0.98 N (100 gf)	B3F-6000	B3F-6100
			High-force	1.47 N (150 gf)	B3F-6002	B3F-6102
		5.0 x 5.0 mm	General purpose	0.98 N (100 gf)	B3F-6020	B3F-6120
			High-force	1.47 N (150 gf)	B3F-6022	B3F-6122
	Projected type	7.3 x 5.0 mm	General purpose	0.98 N (100 gf)	B3F-6050	B3F-6150
			High-force	1.47 N (150 gf)	B3F-6052	B3F-6152

Note: The above Switches must be ordered in units of 1,000.

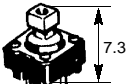
Plunger type	Flat	Projected
Appearance		

■ Accessories (Order Separately)

Special Key Tops are available for projected plunger models. See page NO TAG.

Structure

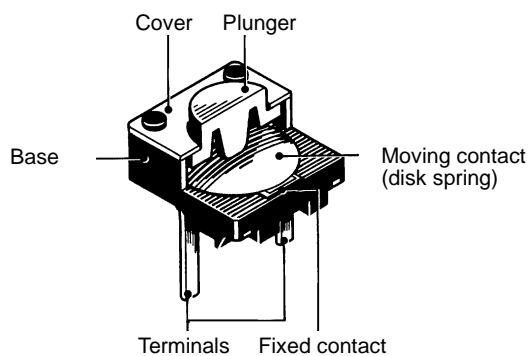

Specifications

■ Ratings

Switching capacity	5 to 24 VDC, 1 to 50 mA (resistive load)
Insulation voltage	30 VDC

■ Characteristics

Contact configuration	SPST-NO
Contact resistance	100 mΩ max. (at 5 VDC, 1 mA)
Insulation resistance	100 MΩ min. (at 250 VDC)
Dielectric strength	500 VAC, 50/60 Hz for 1 min
Bounce time	5 ms max.
Vibration resistance	Malfunction: 10 to 55 Hz, 1.5-mm double amplitude
Shock resistance	Destruction: 1,000 m/s ² min. (approx. 100G min.) Malfunction: 100 m/s ² min. (approx. 10G min.)
Life expectancy	General type: 1,000,000 operations min. High-force type: 300,000 operations min.
Ambient temperature	-25°C to 70°C (with no icing)
Ambient humidity	35% to 85%
Weight	Approx. 0.25 g (flat plunger type, without ground terminal)

■ Operating Characteristics

Model	B3F-6000	
	General purpose	High-force
Operating force (OF)	0.98±0.92 N (100±30 gf)	1.47±0.49 N (150±50 gf)
Reset force (RF min.)	0.2 N (20 gf)	0.49 N (50 gf)
Pretravel (PT)	0.25 ^{+0.2} / _{-0.1} mm	

Engineering Data

Operating Force vs. Stroke (Typical)
B3F-6000

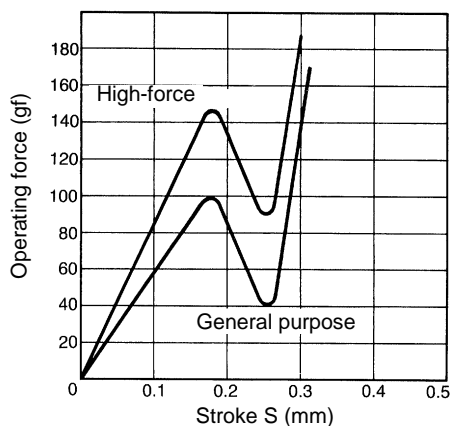

Dimensions

Note: All units are in millimeters unless otherwise indicated. Unless otherwise specified, a tolerance of ± 0.4 mm applies to all dimensions.

Flat Plunger Type (without Ground Terminal) B3F-6000, -6002

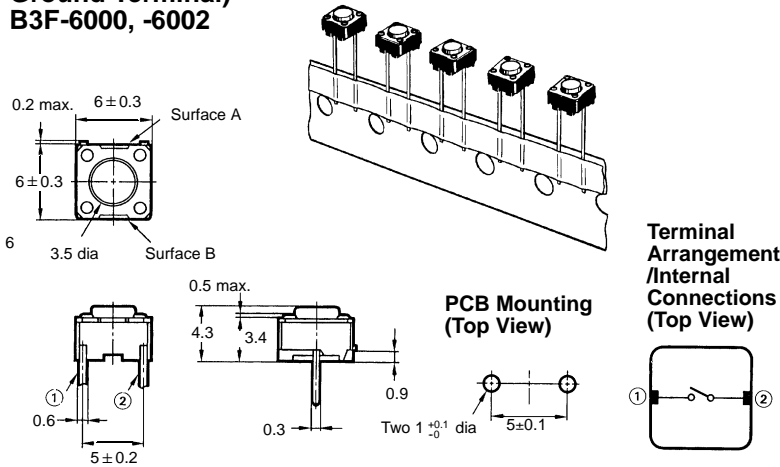

Tape-packaging Dimensions

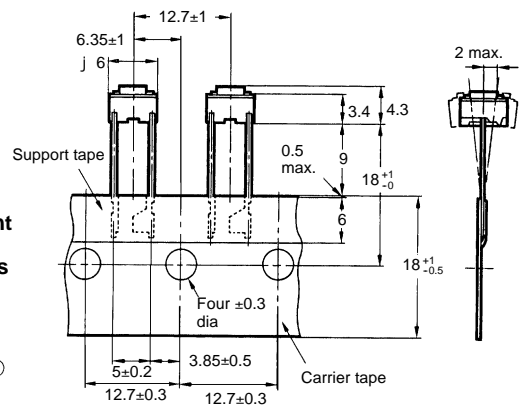

Note: The tape is random between surface A and surface B.

Flat Plunger Type (with Ground Terminal) B3F-6100, -6102

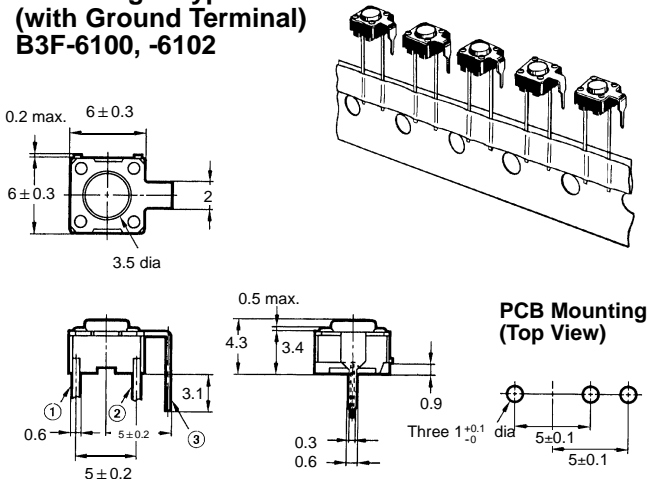

Tape-packaging Dimensions

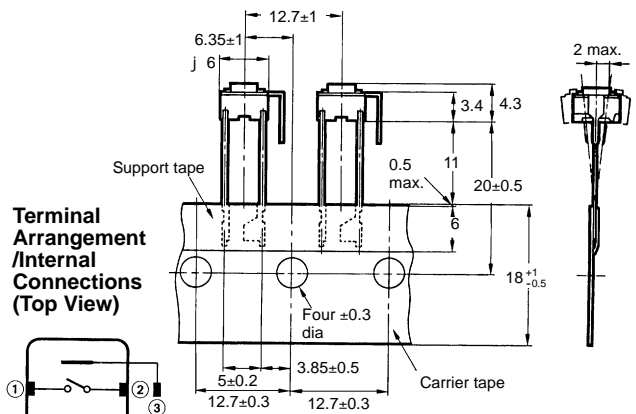

Flat Plunger Type (without Ground Terminal) B3F-6020, -6022

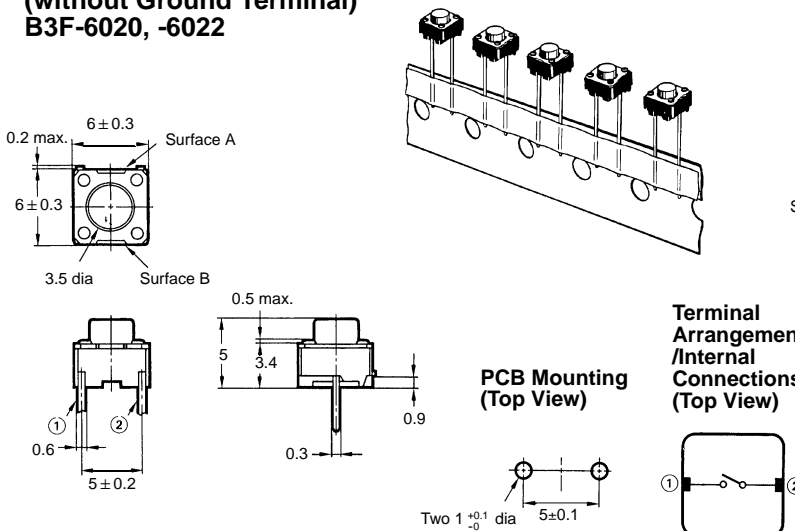

Tape-packaging Dimensions

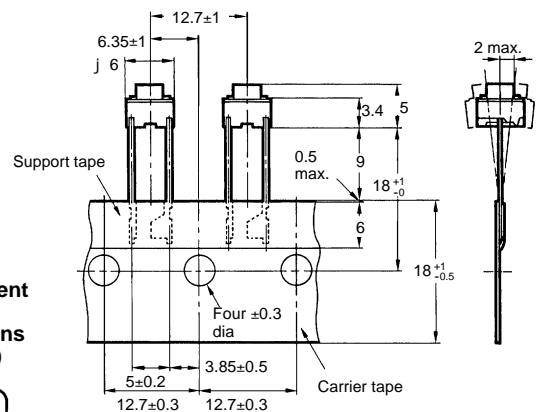

**Flat Plunger Type
(with Ground Terminal)
B3F-6120, -6122**

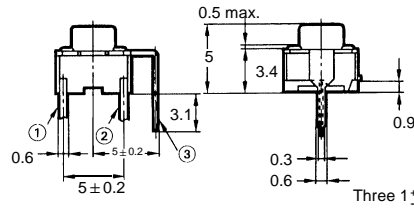
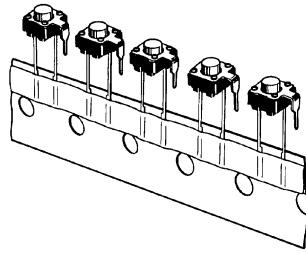
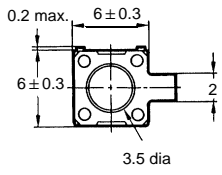

**PCB Mounting
(Top View)**

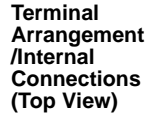

Tape-packaging Dimensions

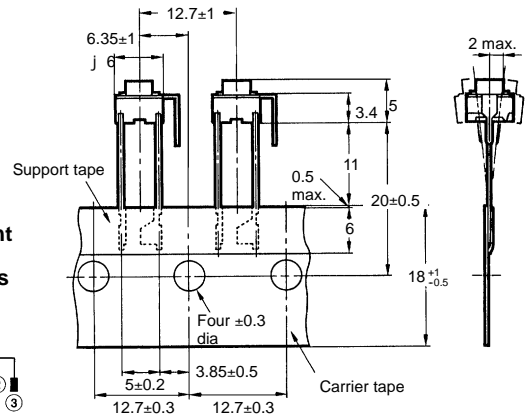

**Projected Plunger Type
(without Ground Terminal)
B3F-6050, -6052**

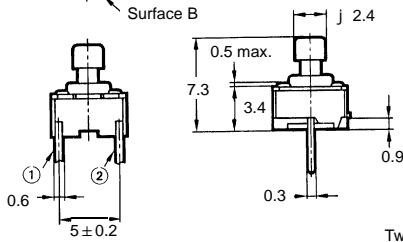
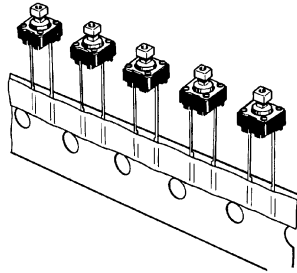
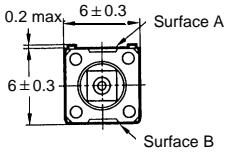

**PCB Mounting
(Top View)**

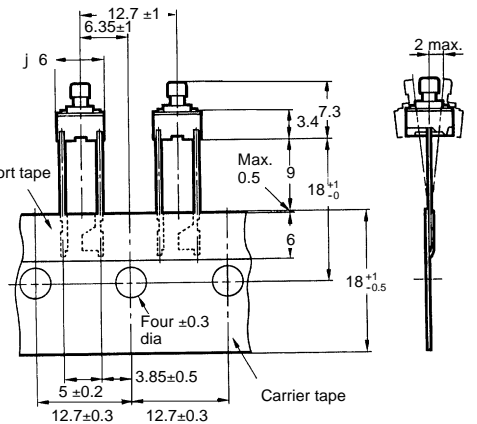
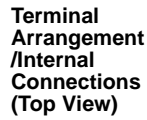

**Projected Plunger Type
(with Ground Terminal)
B3F-6150, -6152**

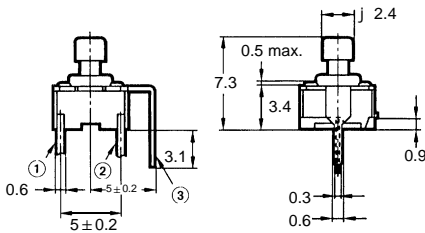
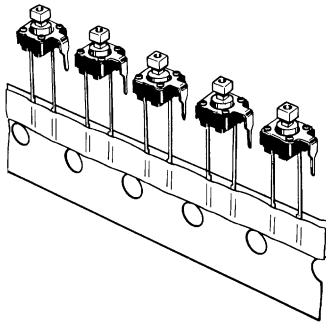
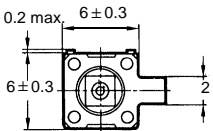

**PCB Mounting
(Top View)**

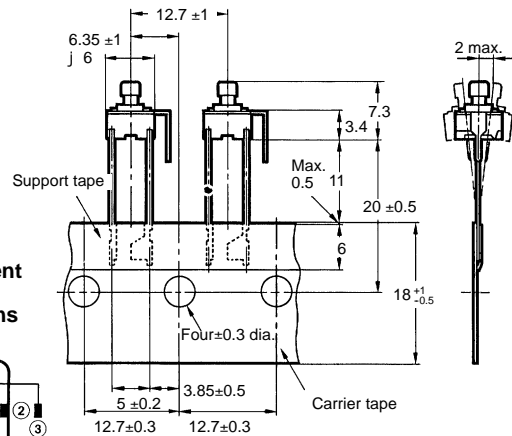
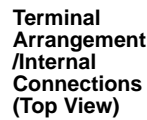

Precautions

- Use a single-sided PCB with a thickness of 1.6 mm. The Switches may be damaged due to instability or heat from soldering if other PCBs (other thickness or through holes) are used. If it is necessary to use another PCB, test the compatibility and processing in advance.
- Do not apply additional force to the plunger once it has stopped moving.
- Solder at $260^{\circ}\pm 5^{\circ}\text{C}$ within five seconds and within two tries.
- Do not wash the Switches. The Switches may be damaged by solvents if either wiped off using solvents or immersed in solvents.
- Do not allow flux or flux foam to penetrate onto the component side of the PCB.
- Do not apply force to Switches packaged on tape, drop them in the packing box, or otherwise subject them to undue force. Doing so may damage the pins.
- The Switches are not sealed and should be protected with a resin sheet as shown below when used in dust-prone environments.

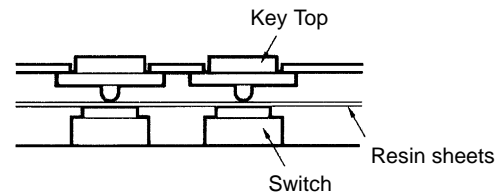

■ Key Switch Packing

- Key Switches packed on tape are placed into packing boxes as shown below.

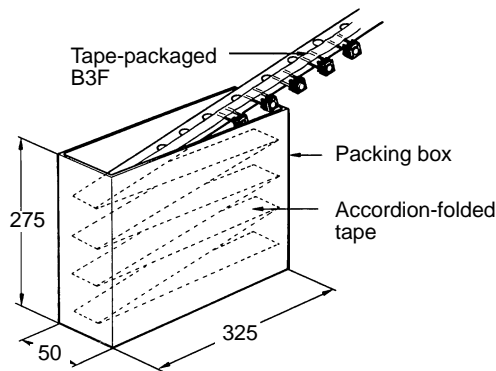

- Tape may be drawn from the box either from the top or from the bottom.

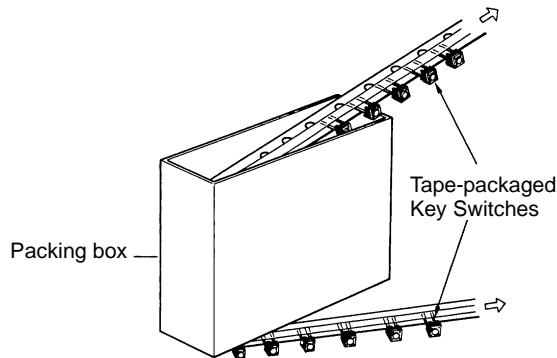

- Number of Switches per box: 1,000

Taping Strength

The Key Switches will not release from the tape when pulled in directions A and B at the following forces.

- A: 4.9 N (500 gf)
- B: 0.98 N (100 gf)

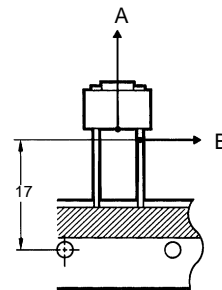

ALL DIMENSIONS SHOWN ARE IN MILLIMETERS.

To convert millimeters into inches, multiply by 0.03937. To convert grams into ounces, multiply by 0.03527.