

Programmable Relay ZEN

Flexible Automation

- Two standard CPU's sizes; 10 I/O & 20 I/O
- All CPU models are extendable with maximum 3 expansion units.
- ZEN 10 I/O expandable up to 34 I/O
- ZEN 20 I/O expandable up to 44 I/O
- Version C1 are with LCD display with 4 lines and 12 characters, 8 programming / control buttons, Inputs / Power Supply, calendar & clock functionality.
- Version C2 is an economic type with LED status
- DC-models have 2 analogue inputs
- Inputs/Power Supply: 24 VDC or 100-240VAC
- Outputs: - Relays, 8A, 250 VAC
- Transistors, 24 VDC, 500 mA
- Programming software optional

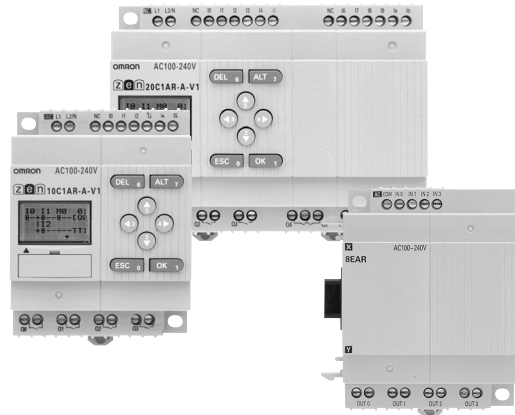

Model Number Structure

Model Number Legend

CPU units

ZEN-□□C□□□□-V1
1 2 3 4 5 6

1 & 2. CPU model

10 10 I/O model
20 20 I/O model

3. Type classifier

1 LCD display, buttons, calendar & clock
2 LED indication

4. Input type

A AC input
D DC input

5. Output type

R Relay output
T Transistor output

6. Supply voltage

A AC power supply
D DC power supply

Expansions units

ZEN-□E□□
1 2 3

1. Number of I/O

8 4 inputs & 4 outputs
4 4 points or 4 outputs

2. Input type

A AC input
D DC input
No input available

3. Output type

R Relay output
T Transistor output
No output available

Ordering Information

■ List of models

Name	No. of I/O points	Display type	Power Supply voltage	Inputs		Outputs		Buttons, calendar & clock	Analog input	Model number
CPU Units	10	LCD	100 to 240 VAC	6	100 to 240 VAC	4	Relays	Yes	No	ZEN-10C1AR-A-V1
		LED						No	No	ZEN-10C2AR-A-V1
		LCD	24 VDC	6	24 VDC	4	Relays	Yes	Yes	ZEN-10C1DR-D-V1
		LED						No	Yes	ZEN-10C2DR-D-V1
		LCD	24 VDC	6	24 VDC	4	Transistors	Yes	Yes	ZEN-10C1DT-D-V1
		LED						No	Yes	ZEN-10C2DT-D-V1
	20	LCD	100 to 240 VAC	12	100 to 240 VAC	8	Relays	Yes	No	ZEN-20C1AR-A-V1
		LED						No	No	ZEN-20C2AR-A-V1
		LCD	24 VDC	12	24 VDC	8	Relays	Yes	Yes	ZEN-20C1DR-D-V1
		LED						No	Yes	ZEN-20C2DR-D-V1
		LCD	24 VDC	12	24 VDC	8	Transistors	Yes	Yes	ZEN-20C1DT-D-V1
		LED						No	Yes	ZEN-20C2DT-D-V1
Expansion I/O Units	8	-		4	100 to 240 VAC	4	Relays	-	-	ZEN-8EAR
		-		4	24 VDC	4	Relays	-	-	ZEN-8EDR
		-		4	24 VDC	4	Transistors	-	-	ZEN-8EDT
	4	-		4	100 to 240 VAC	-	-	-	-	ZEN-4EA
		-		4	24 VDC	-	-	-	-	ZEN-4ED
		-		-	-	4	Relays	-	-	ZEN-4ER

■ Accessories

Name	Specifications	Remarks			Model number
Memory cassette	EEPROM (for data security and copying)	Enables programs and parameter settings to be saved or copied to another ZEN (See note.)			ZEN-ME01
			LCD type	LED type	
		Transfer from ZEN to Memory Cassette	Supported	Not Supported	
		Transfer from Memory Cassette to ZEN	Supported	Supported (Automatic transfer when power turned ON)	
	Memory Cassette initialization	Supported	Not Supported		
Connecting cable	2-m RS-232C (9-pin sub-D connector)	-			ZEN-CIF01
Battery Unit	10 years min. Battery life (at 25° C)	The program and parameter settings are backed up in the CPU Unit's internal EEPROM and will not be lost. Use the Battery Unit to prevent loss of calendar/clock, holding bits, holding timer present values, counter present values, and other data when the power is turned OFF for an extended time (for 2 days or more at 25° C). This data is otherwise backed up using RAM and a super-capacitor.			ZEN-BAT01
ZEN Support Software	Runs on Windows 95, 98, 2000, ME, XP or NT 4.0.	Specifically designed for the ZEN (CD-ROM).			ZEN-SOFT01-V3

Note: Memory Cassettes created using the CPU Unit can be read to the CPU Unit, regardless of which model is used, however the following points must be taken into consideration.

1. When using a Memory Cassette created with a V1 CPU Unit for a Pre-V1 CPU Unit, use the Memory Cassette within the ranges for the Pre-V1 CPU Unit's timers, holding timers, counters, weekly timers, calendar timers, and displays.
2. When using a Memory Cassette created with a CPU Unit with 20 I/O points for a CPU Unit with 10 I/O points, use only up to 6 inputs and 4 outputs for the I/O bit area.

System Configuration

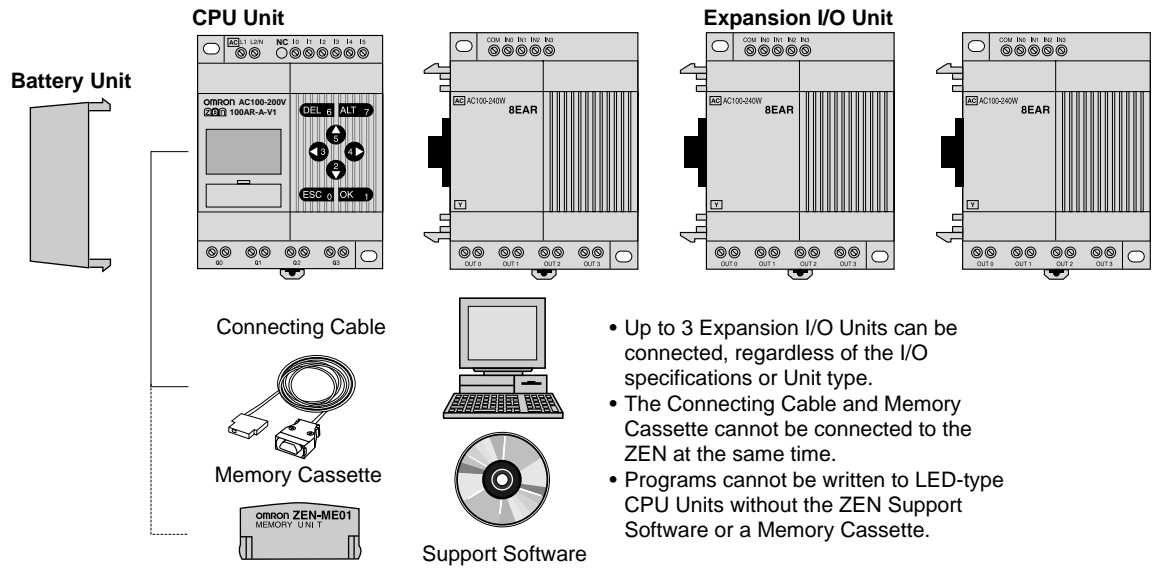

Support Software and CPU Unit Combinations

Support Software Version		ZEN-SOFT01 Ver. 1.00	ZEN-SOFT01-V2 Ver. 2.00	ZEN-SOFT01-V3 Ver. 3.00
Pre-V1 Units		Can be used.	Can be used.	Can be used.
V1 Units	10 I/O points	Can be used, with restrictions (See note.)	Can be used, with restrictions (See note.)	Can be used.
	20 I/O points	Cannot be used.	Cannot be used.	Can be used.

Note: Only half of each of the timer, holding timer, counter, weekly timer, calendar timer, and display function areas can be used (i.e., the Pre-V1 bit range).

Specifications

■ General Specifications

Item	Specification	
	ZEN-□0C□AR-A-V1	ZEN-□0C□D□-D-V1
Power supply voltage	100 to 240 VAC	24 VDC
Rated power supply voltage	85 to 264 VAC	20.4 to 26.4 VDC
Power consumption	30 VA max. (With 3 Expansion Units connected)	6.5 W max. (With 3 Expansion Units connected)
Inrush current	40 A max.	10 A max.
Insulation resistance	Between power supply AC external and input terminals, and relay output terminals: 20 M _Ω min. (at 500 VDC)	
Dielectric strength	Between power supply AC external and input terminals, and relay output terminals: 2,300 VAC, 50/60 Hz for 1 minute with leakage current of 1 mA max.	
Noise immunity	Conforms to IEC61000-4-4, 2 kV (power supply line)	
Vibration resistance	Conforms to JIS C0040, 10 to 57 Hz, amplitude 0.075 mm, 57 to 1,500 Hz, acceleration: 9.8 m/s ² 80 minutes in X, Y, and Z directions (sweep time: 8 min (No. sweeps: 10 = 80 min.))	
Shock resistance	Conforms to JIS C0041. 147 m/s ² , 3 times in X, Y, and Z directions.	
Ambient temperature	LCD-type CPU Unit (operation panel and calendar/clock function): 0 to 55°C LED-type CPU Unit (no operation panel or calendar/clock function): -25 to 55°C	
Ambient humidity	10% to 90% (with no condensation)	
Ambient conditions	No corrosive gases	
Ambient storage temperature	LCD-type CPU Unit (operation panel and calendar/clock function): -20 to 75°C LED-type CPU Unit (no operation panel or calendar/clock function): -40 to 75°C	

■ Performance Specifications

Item	Specification
Control method	Stored program control
I/O control method	Cyclic scan
Programming language	Ladder diagram
Program capacity	96 lines (3 input conditions and 1 output per line)
Max. No. of control I/O points	44 points CPU Unit: 12 inputs and 8 outputs Expansion I/O Units: 4 inputs and 4 outputs each, up to 3 Units.
LCD display	12 characters x 4 lines, with backlight (LCD-type CPU Unit only)
Operation keys	8 (4 cursor keys and 4 operation keys) (LCD-type CPU Unit only)
Memory backup	Internal EEPROM (or optional Memory Cassette) <ul style="list-style-type: none"> • User programs • Parameter settings Internal RAM, super-capacitor hold (or optional Battery Unit) <ul style="list-style-type: none"> • Holding bits • Holding timer and counter values Super capacitor hold (or optional Battery Unit) <ul style="list-style-type: none"> • Calendar and clock
Super-capacitor holding time	2 days min. (25°C)
Battery life (ZEN-BAT01)	10 years min. (25°C)
Time function (RTC)	ZEN□0C1□□-□ only, accuracy: 1 to 2 min/month (at 25°C)
Terminal block	Solid-line terminal block (Use solid lines or fine wiring terminals.)
Power supply holding time	ZEN-□0C□AR-A: 10 ms min. ZEN-□0C□D□-D: 2 ms min.
Weight	300 g max.

Input Specification

CPU Unit

AC Inputs (Not Isolated)

Item	Specifications	Circuit drawing
Input voltage	100 to 240 VAC +10%, -15%, 50/60 Hz	
Input impedance	680 kΩ	
Input current	0.15 mA/100 VAC, 0.35 mA/240 VAC	
ON voltage	80 VAC min.	
OFF voltage	25 VAC max.	
ON response time	50 ms or 70 ms at 100 VAC (See note.)	
OFF response time	100 ms or 120 ms at 240 VAC (See note.)	

Note: Can be selected using the input filter settings

DC Inputs I0 to I3 (I0 to I9 for Units with 20 I/O points), V1 Units (Photocoupler Isolated).

Item	Specifications	Circuit drawing
Input voltage	24 VDC +10%, -15%	
Input impedance	5 kΩ	
Input current	5 mA (typ.)	
ON voltage	16.0 VDC min.	
OFF voltage	5.0 VDC max.	
ON response time	15 ms or 50 ms (See note.)	
OFF response time		

Note: Can be selected using the input filter settings

DC Inputs I14 and I15 (Ia and Ib for Units with 20 I/O points), V1 Units (Not Isolated)

Item	Specifications	Circuit drawing	
DC inputs	Input voltage	24 VDC +10%, -15%	
	Input impedance	5 kΩ	
	Input current	5 mA (typ.)	
	ON voltage	14.0 VDC min.	
	OFF voltage	4.5 VDC max.	
	ON response time	15 ms or 50 ms (See note.)	
	OFF response time		
Analog inputs	Input range	0 to 10 V	
	External input impedance	150 k_ min.	
	Resolution	0.1 V (1/100 FS)	
	Overall accuracy (-25 to 55°C)	10% FS	
	AD conversion data	0 to 10.5 V (in increments of 0.1 V)	

When connecting analog I/O devices, always connect the negative (-) side to the COM terminal.

Note: Can be selected using the input filter settings.

Expansion I/O Unit

AC Inputs (Photocoupler Isolated)

Item	Specifications	Circuit drawing
Input voltage	100 to 240 VAC +10%, -15%, 50/60 Hz	
Input impedance	83 kΩ	
Input current	1.2 mA/100 VAC, 2.9 mA/240 VAC	
ON voltage	80 VAC min.	
OFF voltage	25 VAC max.	
ON response time	50 ms or 70 ms at 100 VAC (See note.)	
OFF response time	100 ms or 120 ms at 240 VAC (See note.)	

Note: Can be selected using the input filter settings.

DC Inputs (Photocoupler Isolated)

Item	Specifications	Circuit drawing
Input voltage	24 VDC +10%, -15%	
Input impedance	4.7 kΩ	
Input current	5 mA (typ.)	
ON voltage	16.0 VDC min.	
OFF voltage	5.0 VDC max.	
ON response time	15 ms or 50 ms (See note.)	
OFF response time		

Note: Can be selected using the input filter settings.

Output Specifications (CPU Unit/Expansion I/O Unit)

Relay Output Type

Item	Specifications	Circuit drawing	
Maximum switching capacity	250 VAC/8 A (Resistive load: $\cos\phi=1$) 24 VDC/5 A (Resistive load)		
Minimum switching capacity	5 VDC/10 mA (Resistive load)		
Relay life	Electrical		Resistive load: 50,000 times ($\cos\phi=1$) Inductive load: 50,000 times ($\cos\phi=0.4$)
	Mechanical		
ON response time	15 ms max.		Units with 20 I/O points only
OFF response time	5 ms max.		

The life, under the worst conditions, of the output contacts used in ZEN relay outputs is given in the above table. Guidelines for the normal life of the relays are shown in the diagram on the right.

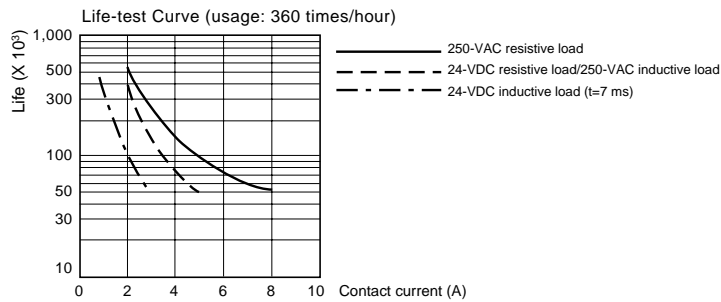

Transistor Output Type

Item	Specifications	Circuit drawing
Maximum switching capacity	24 VDC +10%, -15%, 500 mA	<p>Each circuit is composed of an independent common circuit.</p>
Leakage current	0.1 mA max.	
Residual voltage	1.5 V max.	
ON response time	1 ms max.	
OFF response time	1 ms max.	

Operation

■ Bits

Name	Symbol	Bit addresses	No. of points	Operation			Details ²
Input bits	I	I0 to I _b *	12	Reflect the ON/OFF status of the input devices connected to the input terminals on the CPU Unit.			-
Expansion input bits	X	X0 to X _b	12	Reflect the ON/OFF status of the input devices connected to the input terminals on the Expansion I/O Units.			
Output bits	Q	Q0 to Q ₇ *	8	The ON/OFF status of these output bits is used to control the output devices connected to the output terminals on the CPU Unit.			1
Expansion output bits	Y	Y0 to Y _b	12	The ON/OFF status of these output bits is used to control the output devices connected to the output terminals on the Expansion I/O Units.			
Work bits	M	M0 to M _f	16	Work bits can be used only within the ZEN program. I/Os for external devices cannot be made (i.e., all I/O is internal).			
Holding bits	H	H0 to H _f	16	Used the same as the work bits. However, if the power to the ZEN is turned OFF, these bits also maintain the previous ON/OFF status.			
Timers	T	T0 to T _f	16	X: ON-delay timer ■: (box) OFF-delay timer O: One-shot pulse timer F: Flashing pulse timer	Functions are selected from the screen when parameter settings are made.	Time units can be selected from the following: 0.01-s unit: 0.01 to 99.99 s min/s unit: 00 min 01 s to 99 min 59 s h/s unit: 00 h 01 min to 99 h 59 min	2
Holding timers	#	#0 to #7	8	Hold the present value being counted even if the trigger input or power supply is turned OFF and continue timing when the trigger input or power is restored.			
Counters	C	C0 to C _f	16	Reversible counters that can be incremented and decremented.			3
Weekly timers	@	@0 to @ _f	16	Turn ON and OFF during specified times on specified days.			4
Calendar timers	*	*0 to * _f	16	Turn ON and OFF between specified dates.			5
Display bits	D	D0 to D _f	16	Display any character string, time, or analog-converted display of timer or counter present values.			6
Analog comparator bits	A	A0 to A ₃	4	Used as program input conditions to output analog comparator comparison results. These bits can be used only for 24-VDC input CPU Units.			7
Timer/counter comparator bits	P	P0 to P _f	16	Compare the present values of timers (T), holding timers (#), and counters (C). Comparison can be made between the same two counters or timers, or with constants.			8
Button input bits	B	B0 to B ₇	8	Used as program input conditions and turn ON when operation keys are pressed in RUN Mode. These input bits can be used only with LCD-type CPU Units.			9

Note: * CPU Units with 10 I/O points have 6 input bits (I= to I₅) and 4 output bits (Q0 to Q₃).

² More detail information on the coming pages

1 Additional Bit Output Functions

[: Normal	S: Set	R: Reset	A: Alternate
Q0 will turn ON or OFF depending on the ON/OFF status of the execution condition I0.	Q1 will stay ON once the execution condition I1 has turned ON once. A reset is used to turn Q1 OFF.	Q1 is forced OFF when the execution condition I2 is turned ON.	Q2 alternates between turning ON and OFF when the execution condition I3 turns ON.

2 Using Timers and Holding Timers

Available timers	Holding timers (#0 to #7)	Timers (T0 to Tf)			
Timer type	X	X	■	O	F
	ON-delay timer only	ON-delay timer	OFF-delay timer	One-shot pulse timer	Flashing pulse timer
Operation	Turns ON after set delay after the trigger input turns ON.	Turns ON after set delay after the trigger input turns ON.	Stays ON while the trigger input is ON and turns OFF after a set delay after the trigger input has turned OFF.	Turns ON for a set period after the trigger input turns ON and regardless of how long the trigger input remains ON.	Repeatedly turns ON and OFF in a set cycle while the switch is ON.
Trigger input Reset input Setting Present value Timer input condition					
Main applications	To continue operation after momentary power loss or power interruptions. When delayed operation or a time lag is required.		Useful for OFF delay circuits for lights or fans.	Useful for set operations where operation is always required during a regular period only.	Useful for flashing emergency lights or sounding buzzers as the output for an alarm circuit.

3 Counter Operation

The counter bit turns ON when the counter value (present value) reaches the set value (present value ≥ set value). The count returns to 0 and the counter bit turns OFF when the reset input turns ON. Count inputs are not accepted while the reset input is turned ON. The counter present value and counter bit (ON/OFF) are held even if the operating mode is changed or the power supply is interrupted

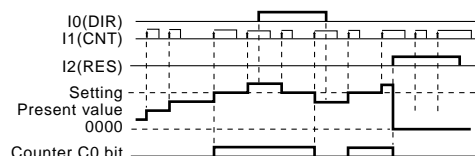

4 Weekly Timer Operation

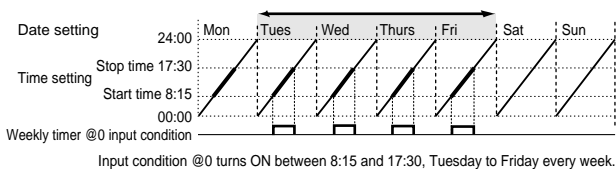

5 Calendar Timer Operation

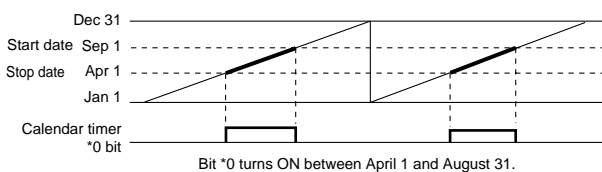

6 Display Settings

Backlight Terminal mode switching	L0: Backlight does not turn ON (ignored if already ON). L1: Backlight turns ON L2: Terminal mode switching (backlight not ON) L3: Terminal mode switching (backlight ON)	
Display start position	X (digit): 00 to 11 Y (line): 0 to 3	<pre> X00 X11 Y0 to Y3 </pre>
Display object	CHR	Characters (up to 12 characters - English, numerals, symbols)
	DAT	Month/day (5 digits □□/□□)
	CLK	Hour/minute (5 digits □□:□□)
	I4 to I5	Analog-converted value (4 digits □□:□□)
	T0 to Tf	Timer present value (5 digits □□.□□)
	#0 to #7	Holding timer present value (5 digits □□.□□)
	C0 to Cf	Counter present value (4 digits □□□□)
Monitoring	A: Can read settings during operation. D: Cannot read settings during operation.	

7 Analog Comparator Operation Example

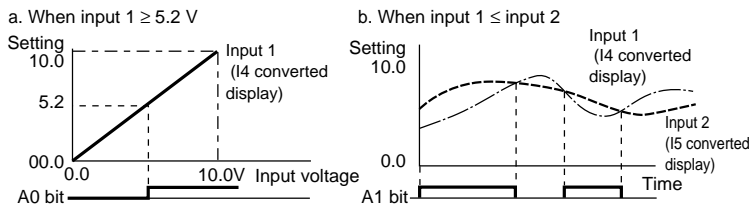

8 Timer/Counter Comparator Operations

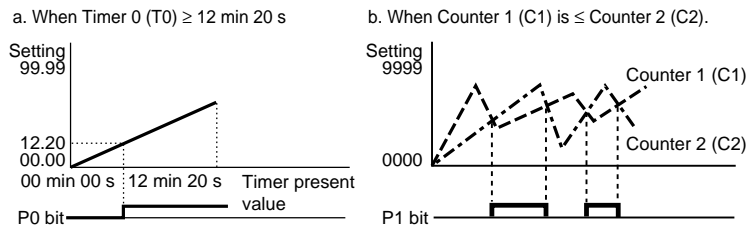

9 Specifications for Button Input Bits

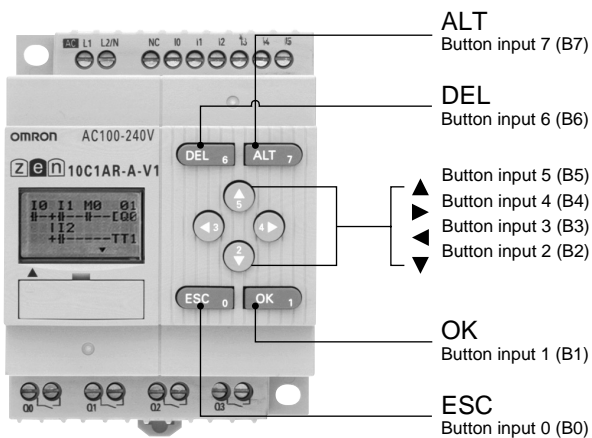

Connections

Input Circuit Wiring

CPU units with 10 I/O points

AC input

CPU Units with 10 I/O Points (V1 and Pre-V1 Units)

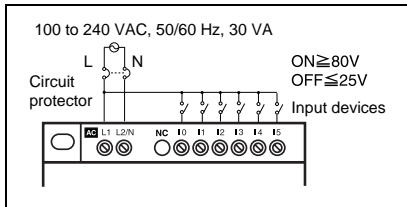

DC input

For connections to negative (-) common (V1 Units) (PNP-connection)

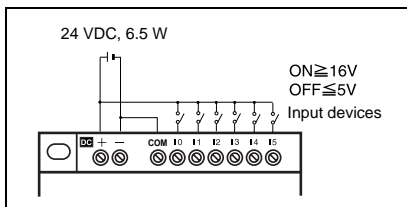

Note: Provide power to the COM and power supply terminals at the same time.

Input terminal I4/I5 analog input device connections (input range: 0 to 10 V) (PNP-connection)

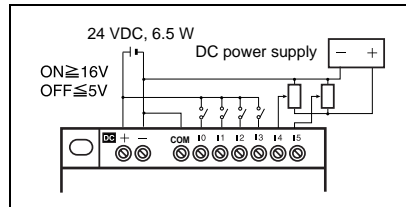

Note: Always connect analog input devices to the negative (-) COM terminal.

For connections to positive (+) common (V1 Units) (NPN-connection)

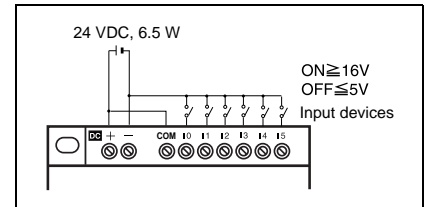

Note: I4/I5 cannot be used as analog input terminals with a positive (+) common terminal connection.

CPU Units with 20 I/O points

AC input

CPU Units with 20 I/O Points

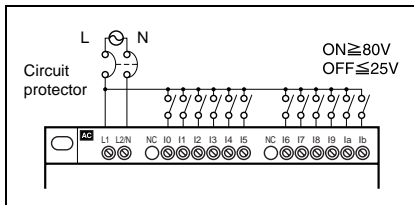

DC input

For connections to negative (-) common (PNP-connection)

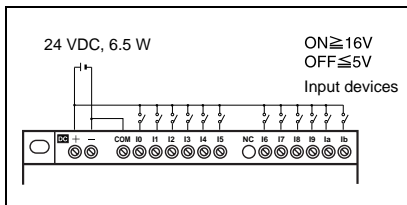

Note: Provide power to the COM and power supply terminals at the same time.

Input terminal Ia/Ib analog input device connections (input range: 0 to 10 V) (PNP-connection)

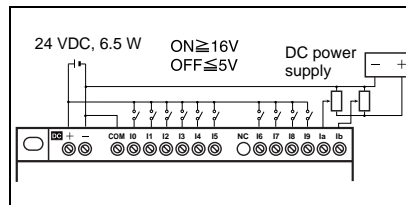

Note: Always connect analog input devices to the negative (-) COM terminal.

For connections to positive (+) common (NPN-connection)

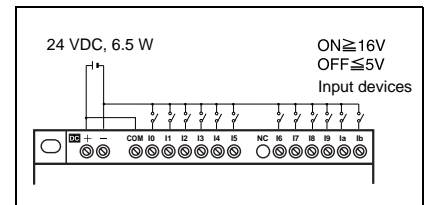

Note: Ia/Ib cannot be used as analog input terminals with a positive (+) common terminal connection.

Note: Provide power to the COM and power supply terminals at the same time.

Expansion I/O Units

AC input

Expansion I/O Units

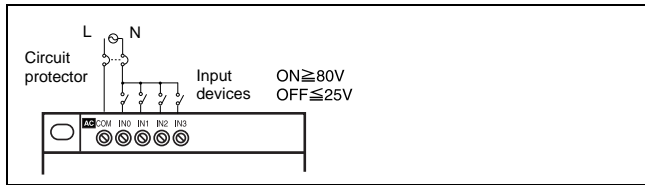

DC input

Expansion I/O Units (DC input type)

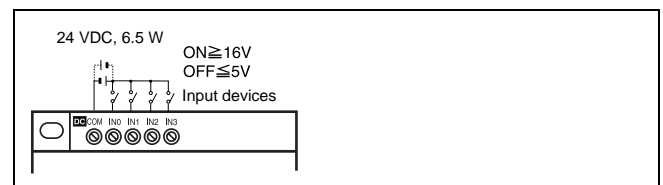

Note: Expansion I/O Units can be connected to either the positive (+) or negative (-) common terminal.

Output Circuit Wiring

CPU units with 10 I/O points

Relay output

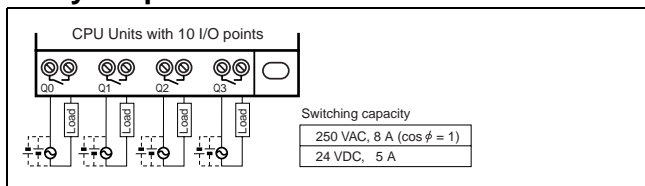

Transistor output

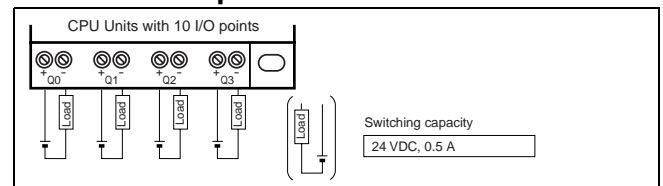

CPU units with 20 I/O points

Relay output

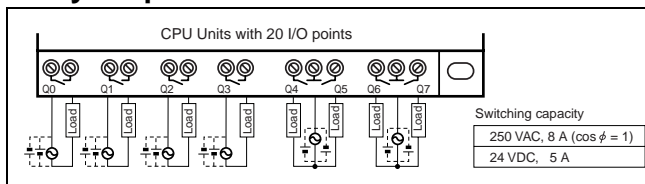

Transistor output

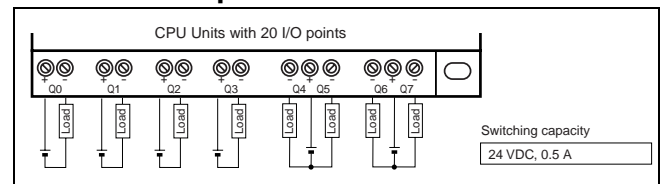

Expansion units with 10 I/O points

Relay output

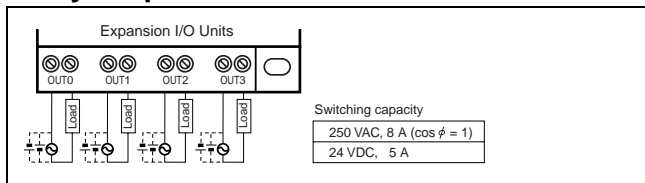

Transistor output

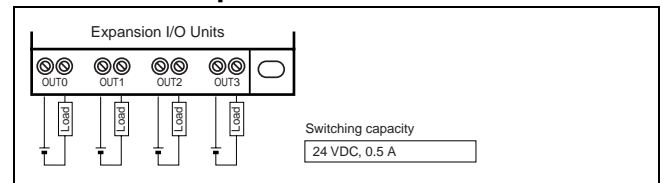

Note: Units with Relay Outputs

All four relay output circuits in both CPU Units with 10 I/O points and Expansion I/O Units have independent contacts. CPU Units with 20 I/O points have 4 independent contacts (Q0 to Q3) and the remaining four (Q4 to Q7) have 2 points/common. There are no restrictions for polarity.

Note: Transistor Output Type

All four transistor output circuits in both CPU Units with 10 I/O points and Expansion I/O Units have independent contacts. CPU Units with 20 I/O points have 4 independent contacts (Q0 to Q3) and the remaining four (Q4 to Q7) have 2 points/common. The terminals have polarity, but the power supply and load connections can be swapped

Nomenclature

■ LCD type

10 I/O Units

Left Side

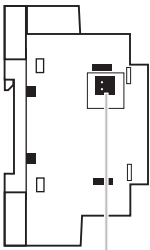

Battery Unit connector
(Remove the seal to connect the Battery Unit.)

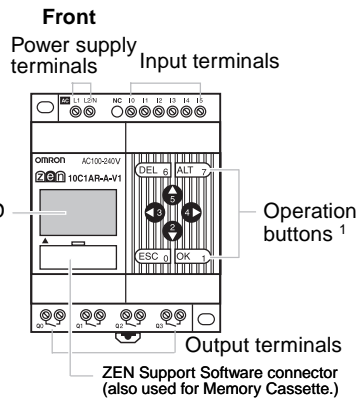

Right Side

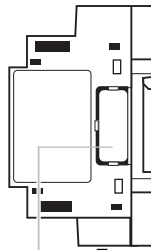

Expansion Unit connector cover.
Remove this cover to connect Expansion Unit.

Icon Meanings



Icon	Meaning
RUN	Displayed while in RUN mode.
ERR	Indicates an error.
▲	Displayed when there is a higher-level menu or ladder program line than the one currently displayed.
▼	Displayed when there is a lower-level menu or ladder program line than the one currently displayed.
○	Displayed when a password has been set.

20 I/O Units

Left Side

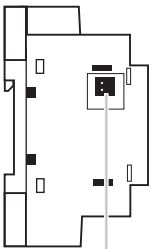

Battery Unit connector
(Remove the seal to connect the Battery Unit.)

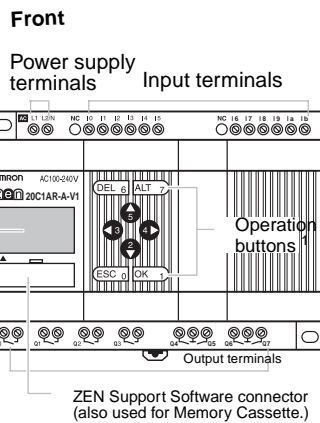

Right Side

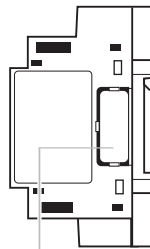

Expansion Unit connector cover.
Remove this cover to connect Expansion Unit.

Note: ¹ See page 9 for Specifications Buttons Input Bits

Display Screen and Basic Operations

The display screen for the LCD-type CPU Units and the operations of the buttons are shown below

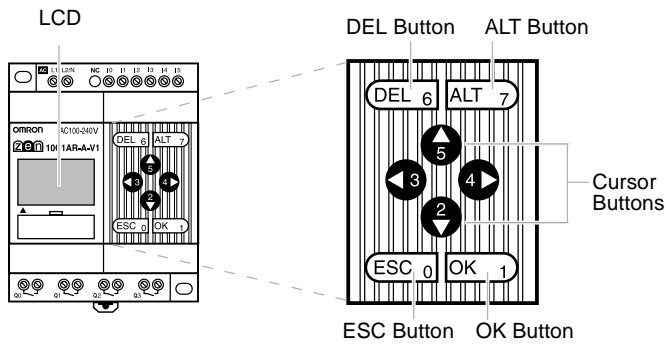

Icon Meanings



Icon	Meaning
RUN	Displayed while in RUN mode.
ERR	Indicates an error.
▲	Displayed when there is a higher-level menu or ladder program line than the one currently displayed.
▼	Displayed when there is a lower-level menu or ladder program line than the one currently displayed.
○	Displayed when a password has been set.

Operation Button Names and Operations

Button	Function			
	Menus	Writing ladder program	Setting parameters	Button switch (See page 9)
DEL	---	Deletes inputs, outputs, connection lines, and blank lines.	---	B6 ON
ALT	---	Switches between normally open and normally closed conditions. Changes to connection line write mode. Inserts a line.	---	B7 ON
Up	Moves the cursor up and down.	Moves the cursor up and down.	Moves the cursor up and down.	B5 ON
Down		Selects bit types and functions.	Changes numerals and parameters.	B2 ON
Left	---	Moves the cursor right and left.	Moves the cursor right and left.	B3 ON
Right			B4 ON	
ESC	Returns to the previous screen.	Cancels the setting and returns to the previous operation.	Cancels the setting and returns to the previous operation.	B0 ON
OK	Selects the menu item at the cursor position.	Confirms the setting.	Confirms the setting.	B1 ON

■ LED type

10 I/O Units

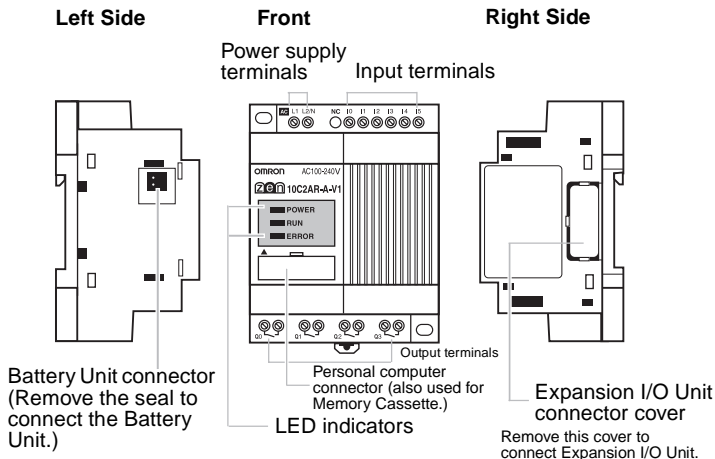

Indicators

Name	Color	Meaning	
POWER	Green	Lit	Power supplied
		Not lit	No power
RUN	Green	Lit	Operating (RUN)
		Not lit	Stopped (STOP)
ERROR	Red	Lit	Error
		Not lit	Normal

20 I/O Units

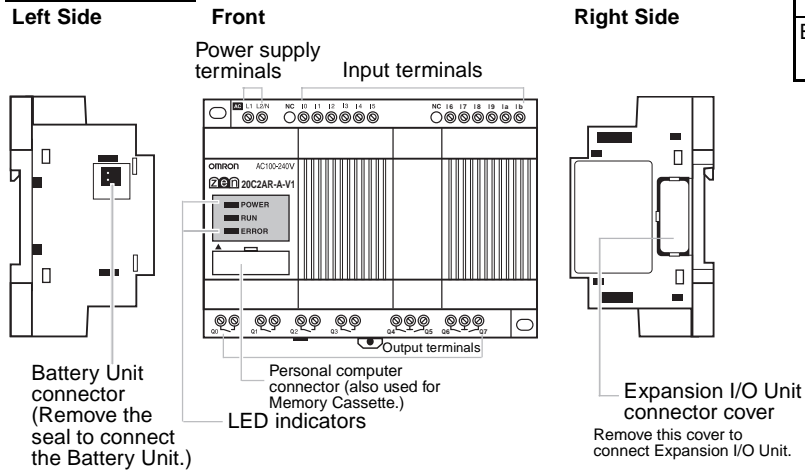

■ Expansion units

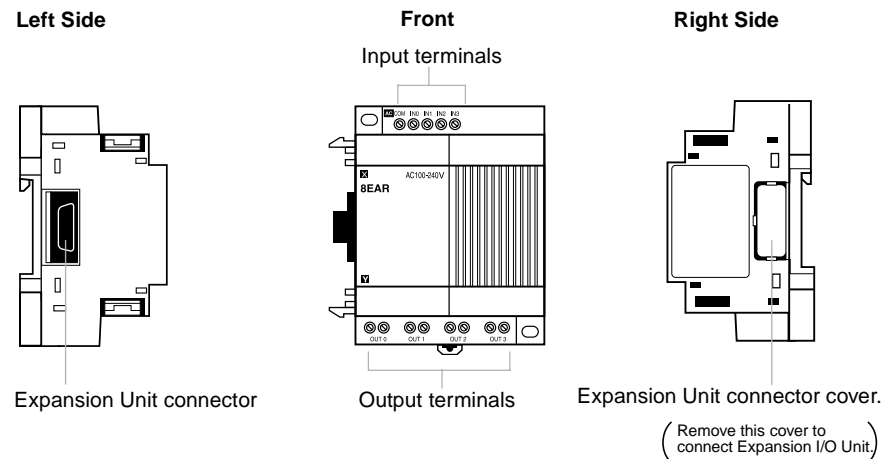

Dimensions (Unit: mm)

CPU Units with 10 I/O Points (LCD/LED Types)

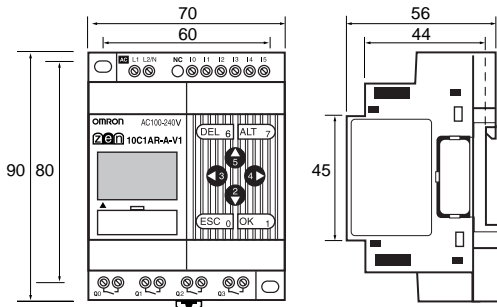

With Battery Unit Mounted

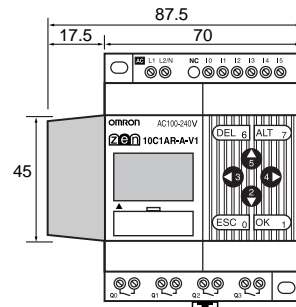

CPU Units with 20 I/O Points (LCD/LED Types)

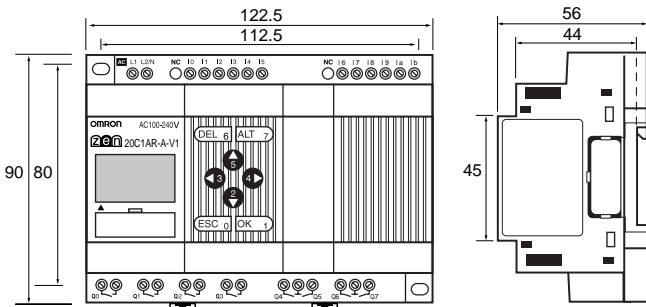

With Battery Unit Mounted

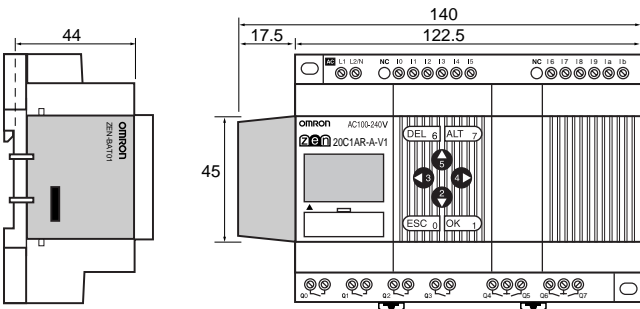

Expansion I/O Units (4 inputs, 4 outputs, 8 I/O)

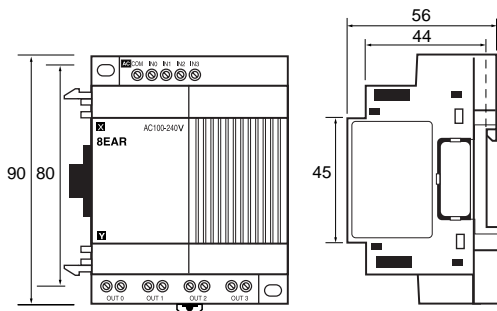

Unit Mounting Hole (Same for all Units)



Precautions

For information on precautions please refer to ZEN operation manual Cat. No. Z183-E1.

Warranty and Application Considerations

Warranty and Limitations of Liability

WARRANTY

OMRON's exclusive warranty is that the products are free from defects in materials and workmanship for a period of one year (or other period if specified) from date of sale by OMRON.

OMRON MAKES NO WARRANTY OR REPRESENTATION, EXPRESS OR IMPLIED, REGARDING NON-INFRINGEMENT, MERCHANTABILITY, OR FITNESS FOR PARTICULAR PURPOSE OF THE PRODUCTS. ANY BUYER OR USER ACKNOWLEDGES THAT THE BUYER OR USER ALONE HAS DETERMINED THAT THE PRODUCTS WILL SUITABLY MEET THE REQUIREMENTS OF THEIR INTENDED USE. OMRON DISCLAIMS ALL OTHER WARRANTIES, EXPRESS OR IMPLIED.

LIMITATIONS OF LIABILITY

OMRON SHALL NOT BE RESPONSIBLE FOR SPECIAL, INDIRECT, OR CONSEQUENTIAL DAMAGES, LOSS OF PROFITS, OR COMMERCIAL LOSS IN ANY WAY CONNECTED WITH THE PRODUCTS, WHETHER SUCH CLAIM IS BASED ON CONTRACT, WARRANTY, NEGLIGENCE, OR STRICT LIABILITY.

In no event shall the responsibility of OMRON for any act exceed the individual price of the product on which liability is asserted.

IN NO EVENT SHALL OMRON BE RESPONSIBLE FOR WARRANTY, REPAIR, OR OTHER CLAIMS REGARDING THE PRODUCTS UNLESS OMRON'S ANALYSIS CONFIRMS THAT THE PRODUCTS WERE PROPERLY HANDLED, STORED, INSTALLED, AND MAINTAINED AND NOT SUBJECT TO CONTAMINATION, ABUSE, MISUSE, OR INAPPROPRIATE MODIFICATION OR REPAIR.

Application Considerations

SUITABILITY FOR USE

OMRON shall not be responsible for conformity with any standards, codes, or regulations that apply to the combination of products in the customer's application or use of the products.

Take all necessary steps to determine the suitability of the product for the systems, machines, and equipment with which it will be used.

Know and observe all prohibitions of use applicable to this product.

NEVER USE THE PRODUCTS FOR AN APPLICATION INVOLVING SERIOUS RISK TO LIFE OR PROPERTY WITHOUT ENSURING THAT THE SYSTEM AS A WHOLE HAS BEEN DESIGNED TO ADDRESS THE RISKS, AND THAT THE OMRON PRODUCTS ARE PROPERLY RATED AND INSTALLED FOR THE INTENDED USE WITHIN THE OVERALL EQUIPMENT OR SYSTEM.

Disclaimers

CHANGE IN SPECIFICATIONS

Product specifications and accessories may be changed at any time based on improvements and other reasons. Consult with your OMRON representative at any time to confirm actual specifications of purchased product.

DIMENSIONS AND WEIGHTS

Dimensions and weights are nominal and are not to be used for manufacturing purposes, even when tolerances are shown.

ALL DIMENSIONS SHOWN ARE IN MILLIMETERS.

To convert millimeters into inches, multiply by 0.03937. To convert grams into ounces, multiply by 0.03527.

Cat. No. L01E-EN-01

In the interest of product improvement, specifications are subject to change without notice.

RFD electronic gmbh

An der Kanzel 2
97253 Gaukönigshofen

Tel.: 09337 / 971230
Fax: 09337 / 9712450
www.rfd-electronic.de