

Rotary Encoder

E6H

High-resolution, Space-saving, General-purpose Rotary Encoder Incorporating Hollow Shaft and Requiring No Coupling

- Resolution of 3,600 pulses/revolution in 40-mm housing.
- Response frequency of 100 kHz.
- Wide operating temperature range of -10°C to 70°C .
- Output cord connected to the side of the body.
- Line driver output available for a maximum length of 100 m.



Ordering Information

Supply voltage	Output configuration	Resolution (P/R)	Model
5 to 24 VDC	Open collector output	300/360/500/600/720/800/1,000/1,024	E6H-CWZ6C
		1,200/1,500/1,800/2,000/2,048	
		2,500/3,600	
5 to 12 VDC	Voltage output	300/360/500/600/720/800/1,000/1,024	E6H-CWZ3E
		1,200/1,500/1,800/2,000/2,048	
		2,500/3,600	
5 to 12 VDC	Line driver output	300/360/500/600/720/800/1,000/1,024	E6H-CWZ3X
		1,200/1,500/1,800/2,000/2,048	
		2,500/3,600	

Note: When ordering, specify the resolution together with the model number.

Specifications

■ Ratings/Characteristics

Item	E6H-CWZ6C	E6H-CWZ3E	E6H-CWZ3X
Power supply voltage	5 VDC -5% to 24 VDC $+15\%$	5 VDC -5% to 12 VDC $+10\%$	5 VDC -5% to 12 VDC $+10\%$
Current consumption	100 mA max.		150 mA max.
Resolution (pulses/rotation)	300/360/500/600/720/800/1,000/1,024/1,200/1,500/1,800/2,000/2,048/2,500/3,600		
Output phases	A, B, and Z (reversible)		
Output configuration	Open collector	Voltage	Line driver (see note 3)
Output capacity	35 VDC max. 35 mA max. Residual voltage: 0.7 V max.	30 mA max. Residual voltage: 0.7 V max.	Output current: H level = I_{O1} = -10 mA L level = I_{S1} = 10 mA Output voltage: H level = V_{O1} = 2.5 V min. L level = V_{S1} = 0.5 V max.
Phase difference on output	$90^{\circ} \pm 45^{\circ}$ between A and B ($1/4T \pm 1/8T$)		
Rise and fall times of output	1 μs max. (control output voltage: 5 V; load resistance: 1 k Ω ; cable length: 0.5 m)		1 μs max. (I_{O1} : -10 mA; I_{S1} : 10 mA; cord length: 0.5 m)
Max. response frequency	100 kHz		
Shaft loading	Radial	29.4 N (3 kgf)	
	Thrust	4.9 N (0.5 kgf)	
Moment of inertia	20 g \cdot cm 2 (2×10^{-6} kg \cdot m 2)		
Starting torque	1.47 N \cdot m (15 gf \cdot cm)		
Max. permissible revolution	10,000 rpm		

Item	E6H-CWZ6C	E6H-CWZ3E	E6H-CWZ3X
Vibration resistance	Destruction: 0 to 500 Hz, 100 m/s ² (10 G) or 1.52-mm double amplitude for 2 hrs each in X, Y, and Z directions		
Shock resistance	Destruction: 300 m/s ² (30G)/11 ms, 3 times each in X, Y, and Z directions (excluding any shock to shaft)		
Insulation resistance/Dielectric strength	Excluded due to capacitor grounding		
Ambient temperature	Operating: -10°C to 70°C Storage: -30°C to 85°C		
Ambient humidity	Operating: 90% max.		
Degree of protection (see note 2)	IEC60529 IP50		
Weight	Approx. 120 g (cord length: 0.5 m)		

Note: 1. The maximum electrical response rotation is determined based on the resolution and maximum response frequency.

$$\text{Maximum electrical response rotation (rpm)} = \frac{\text{Maximum response frequency}}{\text{Resolution}} \times 60$$

Therefore, electrical follow-up will not be achieved if rotated beyond the maximum response rotation.

- No protection is provided against water or oil.
- The line driver output is a data transmission circuit that complies with RS-422A and allows a long distance transmission using a twisted-pair cable. (Equivalent to AM26LS31)

Operation

Output Circuit

E6H-CWZ6C

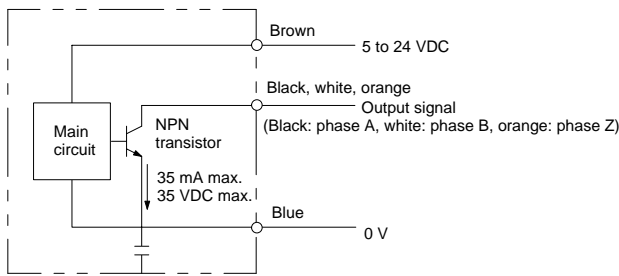

E6H-CWZ3E

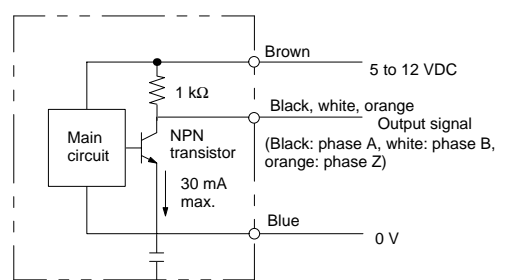

E6H-CWZ3X

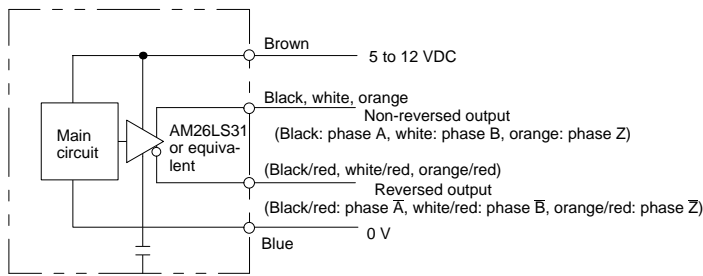

Timing Charts

Open Collector Output

E6H-CWZ6C

Direction of resolution: CW
(As viewed from the end of the shaft)

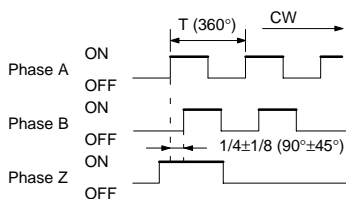

Direction of resolution: CCW
(As viewed from the end of the shaft)

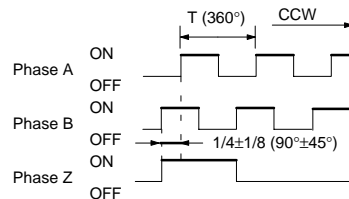

Voltage Output

E6H-CWZ3E

Direction of resolution: CW
(As viewed from the end of the shaft)

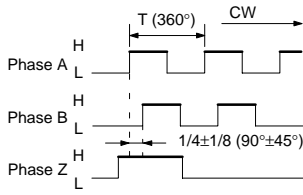

Direction of resolution: CCW
(As viewed from the end of the shaft)

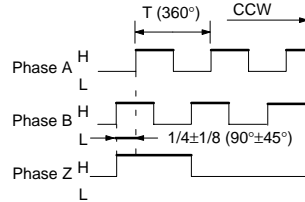

Line Driver Output

E3H-CWZ3X

Direction of resolution: CW
(As viewed from the end of the shaft)

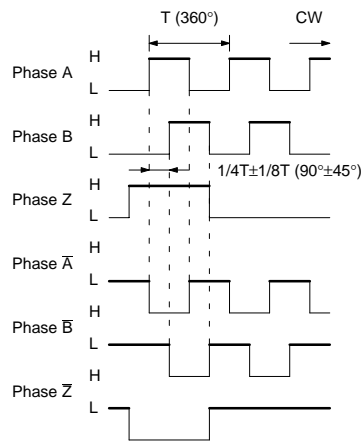

Direction of resolution: CCW
(As viewed from the end of the shaft)

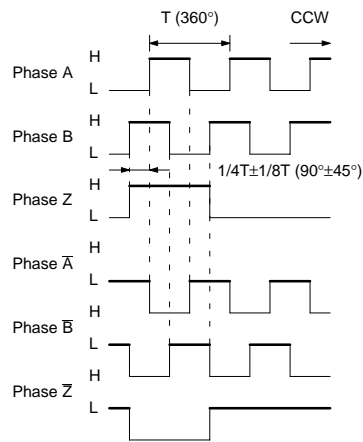

Dimensions

Note: All units are in millimeters unless otherwise indicated.

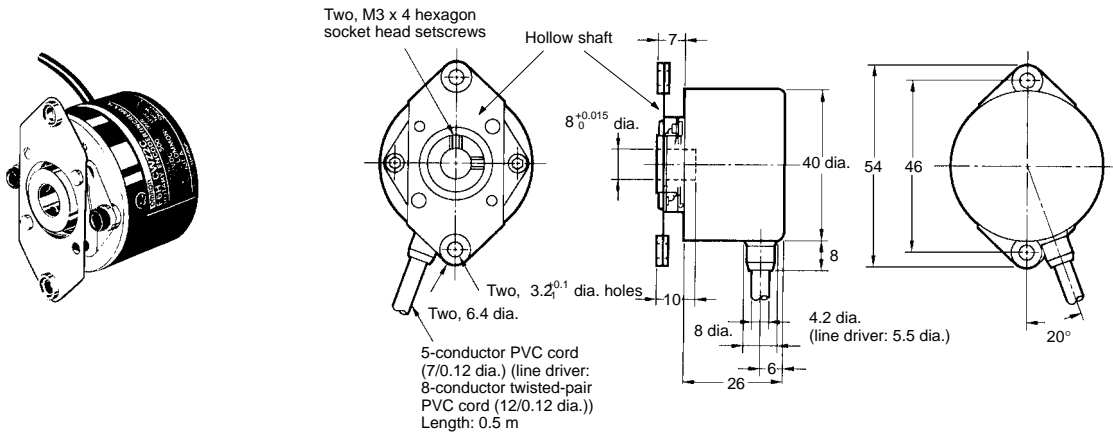

Installation

Be sure to connect the external terminals correctly or the E6H Rotary Encoder may be damaged.

E6H-CWZ6C/CWZ3E

Color	Terminal
Brown	Power supply (+V _{CC})
Black	Output phase A
White	Output phase B
Orange	Output phase Z
Blue	0 V

E6H-CWZ3X

Color	Terminal
Brown	Power supply (+V _{CC})
Black	Output phase A
Black/red	Output phase \bar{A}
White	Output phase B
White/red	Output phase \bar{B}
Orange	Output phase Z
Orange/red	Output phase \bar{Z}
Blue	0 V

- Note:** 1. Receiver: AM26LS32 or equivalent
2. The black/red color indicates a stripe color pattern.

■ Connection with Peripheral Devices

Model	E6H-CWZ6C	E6H-CWZ3E	E6H-CWZ3X
TTL, LSTTL	B	A	C
CMOS	B	A	C
Sensor Controller (S3D2)	A	A	C
Direction Sensor Unit (E63-WF-5C)	A	A	C
Digital Counter (H7BR, H7CR)	A (see note 2)	A (see note 1 and 2)	C
Digital Tachometer (H7ER)	A (see note 2)	A (see note 1 and 2)	C
Intelligent Signal Processor (K3NR-NB□□□/K3NP-NB□□□)	B	B	C
Line receiver IC	C	C	A
SYSMAC High-speed Counter Unit	A	A	A
Position Control Unit	B	B	A

- Note:** A: Possible to connect directly in most cases.
B: Possible to connect, but an independent power supply or pull-up resistor will be required.
C: Impossible to connect.

- Note:** 1. Encoder supply voltage: 12-VDC models only
2. Necessary to select a counter input that matches the encoder output.

Connection of Shaft

Connect to the E6H Rotary Encoder to a shaft with a diameter of 8–0.004/0.012. The length of the shaft must be 8 to 11 mm from the mounting panel.

The tolerance of the shaft to be connected to the E6H Rotary Encoder must be 0.05 mm maximum in the radial direction and 0.3 mm maximum in the thrust direction.

The crossing angle of the mounting panel and the shaft must be 90° with a tolerance of 0.03 mm max.

Do not to impose too much force on the flat spring when mounting the E6H Rotary Encoder to the panel.

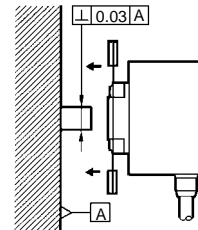

Connection Examples

Connection to H7CR-CW Counter

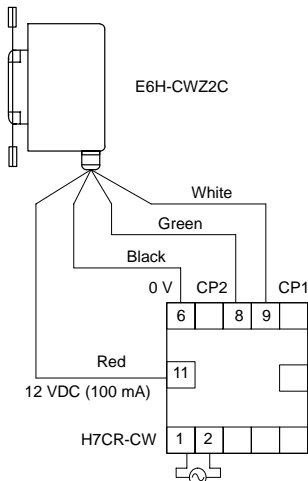

Features of H7CR

DIN-sized (DIN 48) counter incorporating a prescale function converting the measured value to the actual value.

Synchronized output and \pm indication are available (\pm area models).

Models with a general-purpose six-digit display and four-digit display are available.

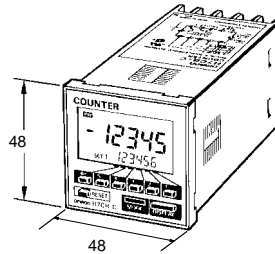

Connection to K3NR-NB□□□/K3NP-NB□□□ Rotary Intelligent Signal Processor

Features of K3NR/K3NP

Each model incorporates a prescale function with an input range of 50 kHz and the measurement accuracy is 0.006%.

A variety of outputs including relay, transistor, BCD, linear, and communications outputs are available.

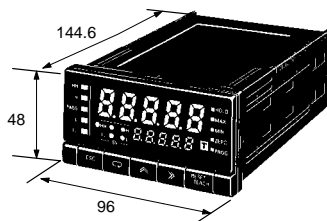

Precautions

Mounting

Be careful not to spray water or oil onto the E6H Rotary Encoder. The E6H Rotary Encoder consists of high-precision components. Handle with utmost care and do not drop the Rotary Encoder, otherwise malfunctioning may result.

When connecting a rotating shaft to the hollow shaft of the E6H Rotary Encoder, the tolerance must be 0.05 mm max. in the radial direction and 0.3 mm max. in the thrust direction, otherwise the hollow shaft will be decentered and the flat spring of the E6H Rotary Encoder may be damaged.

When mounting the E6H Rotary Encoder on a panel, use two M3 screws and attach the flat panel of the Encoder to the mounting panel.

Connect the shaft to the hollow shaft and secure them tightly with hexagon socket head setscrews. The setscrews are provided with the E6H Rotary Encoder. Apply a tightening torque of 0.4 N • m (4 kgf • cm) to secure the setscrews. After tightening the screws, apply locking glue to the setscrews.

Do not pull the cord of the E6H Rotary Encoder after the E6H Rotary Encoder is mounted to a panel. Do not apply any shock to the hollow shaft or the body.

When the E6H Rotary Encoder is used in reversed operation, pay utmost attention to the mounting direction of the E6H Rotary Encoder and the directions of increment and decrement rotation.

To match phase Z of the E6H Rotary Encoder and the origin of the device to be connected to the E6H Rotary Encoder, conform the phase Z output while connecting the device.

Wiring/Connection

Do not reverse polarity when connecting the power supply, otherwise the internal circuitry of the E6H Rotary Encoder may be damaged.

Do not wire power lines or high-tension lines along with the power supply lines of the E6H Rotary Encoder or the E6H Rotary Encoder may be damaged or malfunction.

The cord can be extended up to 2 meters. By using the E6H Rotary Encoder with a line driver output, the cord can be extended up to 100 meters. The receiver circuit requires an RS-422A line receiver. In order to reduce inductive noise as much as possible, the cord must be as short as possible, especially when the signal is input to an IC.

Insert a surge absorber between the power supply terminals if there is any surge.

A wrong pulse may be generated when the E6H Rotary Encoder is turned on or off. Do not use the connected device for 0.1 s after the E6H Rotary Encoder is turned on and for 0.1 s before the E6H Rotary Encoder is turned off.

Make sure the E6H Rotary Encoder is supplied with 5 VDC when a line driver output is used. There will be a 1-V voltage drop approximately if the cable length is 100 m.

Preventing Miscounting

If the operation of the E6H Rotary Encoder is stopped near a signal rising or falling edge, a wrong pulse may be generated, in which case the E6H Rotary Encoder will miscount. In such a case, use an increment-decrement counter to prevent miscounting.

ALL DIMENSIONS SHOWN ARE IN MILLIMETERS.

To convert millimeters into inches, multiply by 0.03937. To convert grams into ounces, multiply by 0.03527.